

**Outsulation MD / Outsulation MD NC
System Application Instructions**

Table of Contents

Section 1	General Installation Requirements
Section 2	Materials Required for Completing Installation of the Outsulation MD System
Section 3	Mixing Instructions
Section 4	Rough Opening Preparation Options
Section 5	Substrate Expansion Joint Bridging Options
Section 6	Air/Water-Resistive Barrier Application
Section 7	Installation of Dryvit Starter Strip, Dryvit Vent Assembly™, Dryvit Vent Track™, Dryvit Track and Dryvit AquaDuct
Section 8	Installation of Insulation Board and Closure Blocks
Section 9	Installation of Reinforcing Mesh and Base Coat
Section 10	Sealant Joint Preparation
Section 11	Dryvit® Primers
Section 12	Dryvit Finish
Section 13	Coatings and Sealers
Section 14	Maintenance and Repair

1. General Installation Requirements

1.1. Project Conditions

1.1.1. Storage

- 1.1.1.1. Maximum storage temperature shall not exceed 38 °C (100 °F). Minimum storage temperature shall not be less than 4 °C (40 °F) with the exception of the following products:
- 1.1.1.2. Demandit™, Revyvite™: 7 °C (45 °F).
- 1.1.1.3. Ameristone™, TerraNeo™ and Limestone™: 10 °C (50 °F).
- 1.1.1.4. Custom Brick™ Finish: refer to Custom Brick Polymer Specification, DSC151.
- 1.1.1.5. For other products, refer to specific product data sheets.

1.1.2. Application

- 1.1.2.1. Application of wet materials shall not take place during inclement weather unless appropriate protection is provided.
- 1.1.2.2. Protect materials from inclement weather until they are completely dry.
- 1.1.2.3. Air and surface temperatures must be 4 °C (40 °F) or above and must remain so for a minimum of 24 hours or until dry at the time of Dryvit product application with the exception of the following products:
 - 1.1.2.3.(1) Demandit, Revyvite: 7 °C (45 °F).
 - 1.1.2.3.(2) Ameristone, TerraNeo and Limestone: 10 °C (50 °F).
 - 1.1.2.3.(3) Custom Brick Finish: refer to Custom Brick Polymer Specification, DSC151.
 - 1.1.2.3.(4) For other products, refer to specific product data sheets.
 - 1.1.2.3.(5) These temperatures shall be maintained with adequate air ventilation and circulation for a minimum of 24 hours (48 hours for Ameristone, TerraNeo and Limestone) thereafter, or until the products are completely dry. Cool, humid conditions may require longer drying times.

1.2. Inspection of Substrate

- 1.2.1. Acceptable substrates for application of the Dryvit Outsulation MD System are listed in the Dryvit Outsulation MD System Specifications, DSC168NC.
- 1.2.2. Wall sheathing must be securely fastened per contract documents.
- 1.2.3. The substrate attachment method must comply with all contract documents.
- 1.2.4. The substrate must be clean, dry, structurally sound, free of loose material, voids, projections, hot spots, release agents, coatings, or other materials that may affect adhesion.
- 1.2.5. There shall be no planar irregularities greater than 6.4 mm (1/4 in) within any 1.2 m (4 ft) radius.
- 1.2.6. Wood based sheathings require a 3.2 mm (1/8 in) gap between adjacent sheets per the guidelines published by the APA.

1.3. Flashing at System Terminations

1.3.1. General

- 1.3.1.1. Ensure that flashing is installed in accordance with applicable code requirements and the contract documents. As a minimum, opening preparation is required as shown in the Outsulation MD System Installation Details, DSC167NC.

1.3.2. Transition at Roof Lines

- 1.3.2.1. Ensure the roof has positive drainage, i.e. all runoff shall be directed to the exterior and away from the structure.
- 1.3.2.2. Roof flashing (by others) shall be installed in accordance with industry guidelines, manufacturer's instructions and contract documents.
- 1.3.2.3. Runoff diverters (i.e. kickouts, crickets and saddles) shall be installed in accordance with industry guidelines, manufacturer's instructions and contract documents. Particular attention must be paid to the eaves/chimney intersections and sloped roof/wall intersections. Refer to the Dryvit Outsulation MD System Installation Details, DSC167NC.
- 1.3.2.4. Hold system a minimum of 203.2 mm (8 in) above flat roofs.

1.3.3. Openings

- 1.3.3.1. Heads, jambs and sills of all openings shall be prepared with Dryvit Backstop™ NT, AquaFlash®, Flashing Tape™ or other approved flashing material selected by the design professional prior to window/door, mechanical equipment, or other component installation. For proper application, refer to the Dryvit Outsulation MD System Installation Details, DSC167NC. **NOTE: Sill piece shall extend to the inside face of wall and continue a minimum of 305 mm (12 in) up at the jambs.**
- 1.3.3.2. Continuous flashing at heads of openings as indicated in contract documents. **NOTE: For windows or doors that do not have integral flashing, a field-applied flashing shall be**

installed (by others) in accordance with industry guidelines, manufacturer's instructions and contract documents. Refer to the Dryvit Outsulation MD System Installation Details, DSC167NC.

- 1.3.3.3. Individual windows that are ganged to make multiple units require that the heads be continuously flashed and the joints between the units must be fully sealed.
- 1.3.4. Decks and Patios
 - 1.3.4.1. Wood decks shall be properly flashed prior to system application. See the Dryvit Outsulation MD System Installation Details, DSC167NC.
 - 1.3.4.2. Verify that the system terminates above poured decks, patios, landings, etc. and that they are properly sloped and waterproofed to direct water away from the walls.
- 1.3.5. Utilities
 - 1.3.5.1. Provisions must be made to ensure that the system terminates properly at lighting fixtures, electrical outlets, hose bibs, dryer vents, etc. Refer to the Dryvit Outsulation MD System Installation Details, DSC167NC.
- 1.3.6. Grade Level Terminations
 - 1.3.6.1. Hold system a minimum of 203.2 mm (8 in) above finished grade.
- 1.4. Sealants
 - 1.4.1. Dryvit materials shall be completely dry prior to installation of sealant materials (typically 48 - 72 hours). Humid or cool conditions may require longer drying times.

Notify the general contractor and/or architect and/or owner of all discrepancies. Do not proceed until all unsatisfactory conditions have been corrected.

2. Materials Required for Completing Installation of the Outsulation MD System

- 2.1. Materials Supplied by Dryvit Systems Canada
 - 2.1.1. AquaFlash and AquaFlash Mesh
 - 2.1.2. Backstop NT Texture, Srim Tape, and AquaFlash Mesh 4"
 - 2.1.3. Dryvit EIFS Tape and Flashing Tape Surface Conditioner™
 - 2.1.4. AP Adhesive
 - 2.1.5. Drainage Vent Track Assemblies
 - 2.1.6. Dryvit AquaDuct: AquaFlash and AquaFlash Mesh
 - 2.1.7. Dryvit Track
 - 2.1.8. Dryvit Vent Track™
 - 2.1.9. Genesis™, Genesis DM, Genesis DMS
 - 2.1.10. Primus®, Primus DM*
 - 2.1.11. Dryflex™
 - 2.1.12. Airsulation™
 - 2.1.13. NCB™
 - 2.1.14. Rapidry DM™ 35-50, Rapidry DM 50-75, RapidPatch™
 - 2.1.15. Standard Mesh, Standard Plus Mesh, Intermediate Mesh, Panzer® 15, Panzer 20, Corner, and Detail Mesh™
 - 2.1.16. Dryvit Finishes
 - 2.1.17. Dryvit Coatings and Primers

*Primus DM is required for Outsulation MD NC.

***Materials listed above are those contained or referenced in the Outsulation MD Specification, DSC167NC. Typically the project specification will identify the specific materials necessary to complete application.**

- 2.2. Materials Supplied by Others
 - 2.2.1. Portland cement: Type 10
 - 2.2.2. Clean Potable Water
 - 2.2.3. Expanded Polystyrene Insulation Board

3. Mixing Instructions

- 3.1. General
 - 3.1.1. No additives such as sand, aggregates, rapid binders, anti-freeze, accelerators, etc. shall be added to any Dryvit materials under any circumstances. **Such additives will adversely affect the performance of the material and void all warranties.**

3.2. Opening Preparation Materials and Water-Resistive Barrier

3.2.1. AquaFlash

3.2.1.1. Open the bucket with a utility knife or lid-off.

3.2.1.2. AquaFlash is ready to use after an initial spin-up using a “Twister” paddle or equivalent mixing blade, powered by a 12.7 mm (1/2 in) drill, at 450 - 500 rpm. Do not add cement or any other additives.

3.2.2. Backstop NT/Airsulation

3.2.2.1. Open the pail with a utility knife or lid removal tool.

3.2.2.2. Due to shipping and storage, there may be some settling of materials. Prior to using, mix the material to a smooth homogeneous consistency using a Wind-lock B-M1 or B-M8, or equivalent, mixing blade powered by a 12.7 mm (1/2 in) drill, at 400-500 rpm.

CAUTION: Do not add cement and do not over-mix or use other types of mixing blades as air entrapment and product damage may occur and result in workability and performance compromise.

3.2.2.3. Do not dilute the product or add any foreign materials to the Backstop NT – Texture or Airsulation product.

3.2.3. Dryflex

3.2.3.1. Open the bucket with a utility knife or lid-off.

3.2.3.2. Due to shipping and storage, there may be some separation of materials. Prior to splitting the material and adding Portland cement, mix the material thoroughly. Use a “Twister” paddle or equivalent mixing blade, powered by a 12.7 mm (1/2 in) drill, at 500 - 1200 rpm.

NOTE: A minimum 7 amp drill works best for Portland cement based materials.

CAUTION: Do not over-mix or use other types of mixing blades as air entrapment and product damage may occur and result in workability and performance problems.

3.2.3.3. Pour 1/2 of the freshly mixed material [approximately 10.21 kg (22.5 lbs)] into a clean plastic container.

3.2.3.4. Add 1/4 of a bag [approximately 10.21 kg (22.5 lbs)] of fresh, lump free Type 10 Portland cement. Either gray or white cement is acceptable. Add cement slowly and mix thoroughly. **Do not add large quantities of cement at one time.**

3.2.3.5. Clean potable water may be added to the mixture to adjust the workability. Add as little water as possible, in small increments, and only after the Portland cement is thoroughly mixed. **Do not over-water as this will degrade the performance of the Outsulation MD System and promote efflorescence. NOTE: It is advisable to mix the Dryflex material with Portland cement thoroughly; then wait five (5) minutes and mix again to break the initial set. Retempering with a small amount of water is permissible provided the mixture has not set. The mixture has a pot life similar to any Portland cement material. Mix only as much material as can be conveniently used during a work period.**

3.3. Adhesive and Base Coat

3.3.1. Primus or Genesis

3.3.1.1. Open the bucket with a utility knife or lid-off.

3.3.1.2. Due to shipping and storage, there may be some separation of materials. Prior to splitting the material and adding Portland cement, mix the material thoroughly. Use a “Twister” paddle or equivalent mixing blade powered by a 12.7 mm (1/2 in) drill, at 500 - 1200 rpm only. **NOTE: A minimum 7 amp drill works best for Portland cement based materials.**

CAUTION: Do not over-mix or use other types of mixing blades as air entrapment and product damage may occur and result in workability and performance problems.

3.3.1.3. Pour 1/2 of the freshly mixed material [approximately 13.5 kg (30 lbs)] into a clean plastic container.

3.3.1.4. Add 1/3 of a bag [approximately 13.5 kg (30 lbs)] of fresh, lump free Type 10 Portland cement. Either gray or white cement is acceptable. Add cement slowly and mix thoroughly. **Do not add large quantities of cement at one time.**

3.3.1.5. Clean potable water may be added to the mixture to adjust the workability.

3.3.1.5.(1) Primus

3.3.1.5.(1)(a) Add as little water as possible, in small increments, and only after the Portland cement is thoroughly mixed. **Do not over water as this will degrade the performance and promote efflorescence.**

- 3.3.1.5.(1)(b) Mix the Primus material with Portland cement thoroughly; then wait five (5) minutes and mix again to break the initial set. Retempering with a small amount of water is permissible provided the mixture has not set. The mixture has a pot life similar to other Portland cement plaster material. Mix only as much material as can be conveniently used during a work period.
- 3.3.1.5.(2) Genesis
- 3.3.1.5.(2)(a) Add 950 ml (1 qt) of water prior to adding Portland cement. Additional water may be added to adjust workability.
- 3.3.1.5.(2)(b) Mix the Genesis material with Portland cement thoroughly; then wait ten to fifteen (10-15) minutes and mix again to break the initial set. Retempering with a small amount of water is permissible provided the mixture has not set. The mixture has a pot life similar to other Portland cement plaster material. Mix only as much material as can be conveniently used during a work period.
- 3.3.2. Primus DM
- 3.3.2.1. Pail Mixing
- 3.3.2.1.(1) One 22.7 kg (50 lb) bag of material will produce approximately 19 L (5 gal) of Primus DM mixture. Add 5.7 L (1.5 gal) of clean potable water into a clean plastic container.
- 3.3.2.1.(2) Add Primus DM slowly while mixing using a "Twister" paddle or equivalent mixing blade, powered by a 12.7 mm (1/2 in) drill, at 500 - 1200 rpm. **NOTE: A minimum 7-amp drill works best for Portland cement based materials.**
- 3.3.2.1.(3) Thoroughly mix until uniformly wetted, adjusting consistency with a small amount of water or Primus DM material.
- 3.3.2.1.(4) Allow the mixture to set a minimum of 5 minutes then retemper, adding a small amount of water if necessary. Material must be free of lumps before using.
- 3.3.2.2. Mortar Mixer
- 3.3.2.2.(1) Add 5.7 L (1.5 gal) of clean potable water for each 22.7 kg (50 lb) bag of Primus DM into a clean mortar mixer.
- 3.3.2.2.(2) Add the Primus DM while the mixer is running. Let mix 3 to 5 minutes, shut mixer off for 5 minutes, then run mixer for another 2 to 3 minutes to break the set and add a small amount of water if necessary to adjust the workability. The pot life is 1 to 3 hours depending on weather.
- 3.3.3. Genesis DM
- 3.3.3.1. Pail Mixing
- 3.3.3.1.(1) One bag of Genesis DM will produce approximately 19 L (5 gal) of Genesis DM mixture. To a clean 19 L (5 gal) pail, add 5.7 - 6.6 L (6 - 7 qt) of clean potable water.
- 3.3.3.1.(2) Add the Genesis DM slowly while constantly mixing with a "Twister" paddle or equivalent mixing blade, powered by a 12.7 mm (1/2 in) drill, at 500 - 1200 rpm. **NOTE: A minimum 7 amp drill works best for Portland cement based materials.**
- 3.3.3.1.(3) Thoroughly mix until uniformly wetted, adjusting consistency with a small amount of water or Genesis DM.
- 3.3.3.1.(4) Let set for 10 minutes. Retemper, adding a small amount of water if necessary. Material must be free of lumps before using.
- 3.3.3.2. Mortar Mixer
- 3.3.3.2.(1) Add 5.7 - 6.6 L (6 - 7 qt) of clean potable water for each 22.7 kg (50 lb.) bag of Genesis DM into a clean mortar mixer.
- 3.3.3.2.(2) Add the Genesis DM while the mixer is running. Let mix 3 to 5 minutes, shut the mixer off for 10 minutes, then run mixer for another 2 to 3 minutes to break the set adding a small amount of water if necessary to adjust workability. The pot life is 1 to 1 1/2 hours depending on weather.
- 3.3.4. Genesis DMS
- 3.3.4.1. Sprayer
- 3.3.4.1.(1) Connect a source of clean, cool potable water to a spray machine suitable for EIFS applications.
- 3.3.4.1.(2) Regulate the water flow rate to provide the desirable mixing consistency of material. Material may thicken up upon leaving the mixing cylinder at given water flow and loosen up after pumping. **NOTE: The consistency for application must be determined after pumping.**

- 3.3.4.2. Pail Mixing
 - 3.3.4.2.(1) One bag of Genesis DMS will produce approximately 19 L (5 gal) of Genesis DMS mixture. To a clean 19 L (5 gal) pail, add 6.6 - 8.5 L (7 - 9 qt) of clean, cool potable water.
 - 3.3.4.2.(2) Add the Genesis DMS slowly while continuously mixing with a “Twister” paddle or equivalent mixing blade, powered by a 12.7 mm (1/2 in) drill, at 500 - 1200 rpm.
NOTE: A minimum 7 amp drill works best for Portland cement based materials.
 - 3.3.4.2.(3) Thoroughly mix until uniformly wetted, adjusting consistency with a small amount of water or Genesis DMS.
 - 3.3.4.2.(4) Let set for 5 minutes. Retemper, adding a small amount of water if necessary. Material must be free of lumps before using.
- 3.3.4.3. Mortar Mixer
 - 3.3.4.3.(1) Add 6.6 - 8.5 L (7 - 9 qt) of clean, cool potable water for each 22.7 kg (50 lb) bag of Genesis DMS into a clean mortar mixer.
 - 3.3.4.3.(2) Add the Genesis DMS while the mixer is running. Let mix 3 to 5 minutes, shut the mixer off for 5 minutes, then run mixer for another 2 to 3 minutes. Retemper, adding a small amount of water if necessary. Material must be free of lumps before using. The pot life is 1 to 3 hours depending on weather.
- 3.3.5. Rapidry DM 35-50
 - 3.3.5.1. Pail Mixing
 - 3.3.5.1.(1) One 22.7 kg (50 lb) bag of Rapidry DM 35-50 will produce approximately 19 L (5 gal) of Rapidry DM mixture. To a clean 19 L (5 gal) pail, add 6.1 L (6.5 qt) of clean potable water. As an alternative, on the inside of the Dryvit 19 L (5 gal) pail, draw a horizontal line which measures 113 mm (4 7/16 in) from the base of the pail and fill with water.
 - 3.3.5.1.(2) Add the Rapidry DM 35-50 slowly while constantly mixing with a “Twister” paddle or equivalent mixing blade, powered by a 12.7 mm (1/2 in) drill, at 500 - 1200 rpm.
NOTE: A minimum 7 amp drill works best for Portland cement based materials.
 - 3.3.5.1.(3) Thoroughly mix until uniformly wetted, adjusting consistency with a small amount of water or Rapidry DM. Material must be free of lumps before using.
 - 3.3.5.2. Mortar Mixer
 - 3.3.5.2.(1) Add 6.1 L (6.5 qt) of clean potable water for each 22.7 kg (50 lb) bag of Rapidry DM 35-50 into a clean mortar mixer.
 - 3.3.5.2.(2) Add the Rapidry DM while the mixer is running. Let mix 3 to 5 minutes. Thoroughly mix until uniformly wetted, adjusting consistency with a small amount of water or Rapidry DM. Material must be free of lumps before using. The pot life is 30 minutes depending on temperature..
- 3.3.6. Rapidry DM 50-75
 - 3.3.6.1. Pail Mixing
 - 3.3.6.1.(1) One 20.4 (45 lb) bag of Rapidry DM 50-75 will produce approximately 19 L (5 gal) of Rapidry DM 50-75 mixture. To a clean Dryvit 19 L (5 gal) pail, add 5.2 L (5.5 qt) of clean potable water. As an alternative, on the inside of the Dryvit 19 L (5 gal) pail, draw a horizontal line which measures 97 mm (3 13/16 in) from the base of the pail and fill with water.
 - 3.3.6.1.(2) Add the Rapidry DM slowly while constantly mixing with a “Twister” paddle or equivalent mixing blade, powered by a 12.7 mm (1/2 in) drill, at 500 - 1200 rpm.
NOTE: A minimum 7 amp drill works best for Portland cement based materials.
 - 3.3.6.1.(3) Thoroughly mix until uniformly wetted, adjusting consistency with a small amount of water or Rapidry DM.
 - 3.3.6.1.(4) Let set for 5 minutes. Retemper, adding a small amount of water if necessary. Material must be free of lumps before using.
 - 3.3.6.2. Mortar Mixer
 - 3.3.6.2.(1) Add 5.2 L (5.5 qt) of clean potable water for each 20.4 kg (45 lb) bag of Rapidry DM 50-75 into a clean mortar mixer.
 - 3.3.6.2.(2) Add the Rapidry DM while the mixer is running. Let mix 3 to 5 minutes, shut the mixer off for 5 minutes, then run mixer for another 2 to 3 minutes to break the set

and add a small amount of water if necessary. The pot life is 30 to 45 minutes depending on temperature.

3.4. Base Coat only

3.4.1. NCB (for combustible construction only)

3.4.1.1. Open the bucket with a utility knife or lid-off.

3.4.1.2. Mix NCB to a smooth, homogeneous consistency with a "Twister" paddle or equivalent mixing blade, powered by a 12.7 mm (1/2 in) drill, at 450 - 500 rpm. A small amount of clean potable water may be added to adjust workability.

3.4.2. Dryflex

3.4.2.1. Open the bucket with a utility knife or lid-off.

3.4.2.2. Due to shipping and storage, there may be some separation of materials. Prior to splitting the material and adding Portland cement, mix the material thoroughly. Use a "Twister" paddle or equivalent mixing blade, powered by a 12.7 mm (1/2 in) drill, at 500 - 1200 rpm.

***NOTE: A minimum 7 amp drill works best for Portland cement based materials.**

CAUTION: Do not over-mix or use other types of mixing blades as air entrapment and product damage may occur and result in workability and performance problems.

3.4.2.3. Pour 1/2 of the freshly mixed material [approximately 10.21 kg (22.5 lbs)] into a clean plastic container.

3.4.2.4. Add 1/4 of a bag [approximately 10.21 kg (22.5 lbs)] of fresh, lump free Type 10 Portland cement. Either gray or white cement is acceptable. Add cement slowly and mix thoroughly. **Do not add large quantities of cement at one time.**

3.4.2.5. Clean potable water may be added to the mixture to adjust the workability. Add as little water as possible, in small increments, and only after the Portland cement is thoroughly mixed. **Do not over-water as this will degrade the performance and promote efflorescence.**

***NOTE: It is advisable to mix the Dryflex material with Portland cement thoroughly; then wait five (5) minutes and mix again to break the initial set. Retempering with a small amount of water is permissible provided the mixture has not set. The mixture has a pot life similar to any Portland cement material. Mix only as much material as can be conveniently used during a work period.**

3.5. Primers

3.5.1. Color Prime™, Primer with Sand™, Weatherprime™, and Prymit™

3.5.1.1. Mix material with a "Twister" paddle or equivalent mixing blade, powered by a 12.7 mm (1/2 in) drill, at 450 - 500 rpm to a homogeneous consistency.

3.6. Finishes

3.6.1. Quarzputz®, Quarzputz E, Sandblast®, Freestyle®, Sandpebble™, Sandpebble E, Sandpebble Fine,

Sandpebble Fine E, and Weatherlastic™ finishes.

3.6.1.1. Thoroughly mix the factory-prepared Dryvit finish with a "Twister" paddle or equivalent mixing blade powered by a 12.7 mm (1/2 in) drill, at 450 - 500 rpm, until a uniform, homogeneous consistency is attained. A small amount of clean potable water may be added to adjust workability. Always add the same amount of water to each pail within a given lot to avoid color variation.

3.7. Specialty Finishes

3.7.1. Ameristone

3.7.1.1. Mix Ameristone for approximately 1 minute to ensure uniformity using a "Twister" paddle or equivalent mixing blade powered by a 12.7 mm (1/2 in) drill, at 450 - 500 rpm, just prior to application. **DO NOT OVERMIX.**

3.7.1.2. Mix all pails for the same amount of time.

3.7.1.3. If clean potable water is added as described in DSC142 for various application techniques, the same amount must be added to each pail.

3.7.2. Stone Mist™

3.7.2.1. Mix Stone Mist for 1 minute to ensure uniformity using a "Twister" paddle or equivalent mixing blade, powered by a 12.7 mm (1/2 in) drill, 450 - 500 rpm, just prior to application. **DO NOT OVERMIX.**

3.7.3. TerraNeo™

- 3.7.3.1. Mix TerraNeo for 1 minute just prior to application, to ensure uniformity using a “Twister” paddle or equivalent mixing blade, powered by a 12.7 mm (1/2 in) drill, at 450 - 500 rpm.
DO NOT OVERMIX.

3.7.4. Limestone

- 3.7.4.1. Mix Limestone with a “Twister” paddle or equivalent mixing blade, powered by a 12.7 mm (1/2 in) drill, at 450 - 500 rpm until a uniform workable consistency is attained.

3.7.5. Custom Brick Finishes

- 3.7.5.1. For Custom Brick finishes, refer to Dryvit Custom Brick Application Instructions, DSC154 and DSC214, for complete mixing instructions.

3.8. Coatings and Sealers

3.8.1. Demandit, Revyvit, Weathercoat™, and Weatherlastic Smooth

- 3.8.1.1. Mix material with a “Twister” paddle or equivalent mixing blade, powered by a 12.7 mm (1/2 in) drill, at 450 - 500 rpm to a homogeneous consistency.

3.8.2. Tuscan Glaze™

- 3.8.2.1. Mix Tuscan Glaze with a “Twister” paddle or equivalent mixing blade, powered by a 12.7 mm (1/2 in) drill, at 450 - 500 rpm to a homogeneous consistency, immediately prior to application. As an alternate, boxing of buckets is acceptable. **Continuously** agitate throughout application to ensure color consistency.

3.8.3. SealClear™

- 3.8.3.1. Stir material thoroughly before using and stir often during the application process. As an alternate, boxing of buckets is acceptable.

4. Rough Opening Preparation Options

4.1. Sill Options

- *Caution: WRB (Water-Resistive Barrier) on their own are not sufficient for treatments of rough opening sills. The sill location of all rough openings must be treated with either of the following sill options:**

- 4.1.1. Dryvit Aquaflash® System

- 4.1.2. Dryvit EIFS Tape

4.2. Jamb Options

- 4.2.1. Dryvit Aquaflash System

- 4.2.2. Dryvit EIFS Tape

- 4.2.3. Dryvit WRB

4.3. Head Options

- 4.3.1. Dryvit Aquaflash System

- 4.3.2. Dryvit EIFS Tape

- 4.3.3. Dryvit WRB

4.4. Dryvit Aquaflash System

- 4.4.1. Refer to Installation Instructions DSC 196

4.5. Dryvit WRB

- 4.5.1. Backstop NT Installation Instructions refer to DSC 177

4.6. Dryvit EIFS Tape Option

- *Caution: The Dryvit EIFS Tape and Surface Conditioner must be handled properly. Refer to the Material Safety Data Sheets for proper handling, storage, health and environmental considerations.**

- *NOTE1: When Dryvit EIFS Tape is specified for rough opening preparation the water resistive barrier must be installed prior to preparing the opening (See Section 6)**

- 4.6.1. Dryvit EIFS Tape must be installed to provide a continuous barrier from the sheathing substrate onto the framing edges at discontinuities and terminations such as openings, expansion joints, tops of parapets, etc. Refer to Dryvit Outsulation MD System Installation Details, DSC167NC.

4.6.2. Surface Preparation

- 4.6.2.1. Apply only when air and surface temperatures are above 4 °C (40 °F).

- 4.6.2.2. The surface to receive the Dryvit EIFS Tape must be clean, dry, smooth and free of any condition that will hinder adhesion.

- 4.6.2.3. Clean loose dust or dirt from the surface by wiping with a clean, dry cloth or brush.

4.6.3. Dryvit EIFS Tape Surface Conditioner Application

- 4.6.3.1. Pour the desired amount of surface conditioner into a clean container to prevent contamination.
- 4.6.3.2. Apply to the surfaces, which are to receive the Dryvit EIFS Tape, using a brush or roller. Sufficient surface conditioner should be applied to condition the surface to a dust free state suitable for the application of the Dryvit EIFS Tape. It should not be applied so heavily that it puddles or runs. Application of excess material will not improve adhesion but will extend the drying time.
- 4.6.3.3. Allow to dry until the surface is slightly tacky. Low temperatures and high humidity conditions may require longer drying times. Conditioning should be limited to areas that can be covered with Dryvit EIFS Tape within the same day.
- 4.6.4. Dryvit EIFS Tape Application
 - 4.6.4.1. General
 - 4.6.4.1.(1) Cut the Dryvit EIFS Tape to the appropriate length. Peel the release paper to expose the rubberized asphalt adhesive and align the tape into position before touching the wall.
 - 4.6.4.1.(2) Position the tape on the wall face so that it covers the Backstop NT 51 mm (2 in) and the remainder is turned into the opening.
 - 4.6.4.1.(3) Move along the opening being careful to put the tape as evenly as possible and avoiding fish-mouths along the edges. If wrinkles develop, cut out the affected area and replace.
 - 4.6.4.1.(4) Apply pressure to the tape so that it is firmly in contact with the wall surface. Press the tape into place with a hand roller as soon as possible to ensure continuous and intimate contact with the surface.
 - 4.6.4.1.(5) End laps that occur must maintain a minimum overlap of 51 mm (2 in).
 - 4.6.4.1.(6) Apply Dryvit EIFS Tape so that it completely covers the stud edges extending to the interior face of the opening. Additional strips of Dryvit EIFS Tape may be needed.
 - 4.6.4.1.(7) Cold weather application may require the use of a heat gun to warm the wall surface in order to obtain good initial adhesion.
 - 4.6.4.2. Sill/jamb intersections and similar conditions
 - 4.6.4.2.(1) Apply the Dryvit EIFS Tape as shown in the detail below - Figure 1.
 - 4.6.4.2.(2) Apply sill piece first, then apply the corner splice piece. The jamb piece is applied next, lapping over the splice piece.

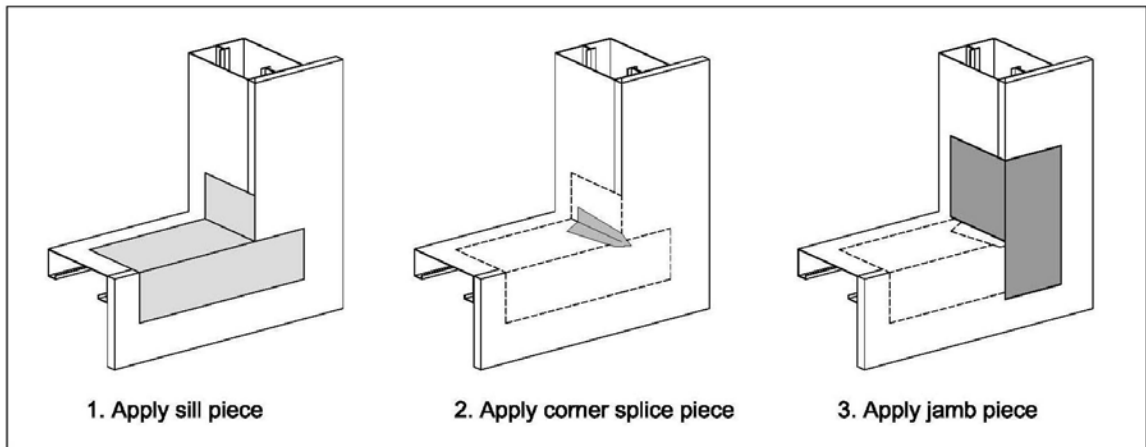
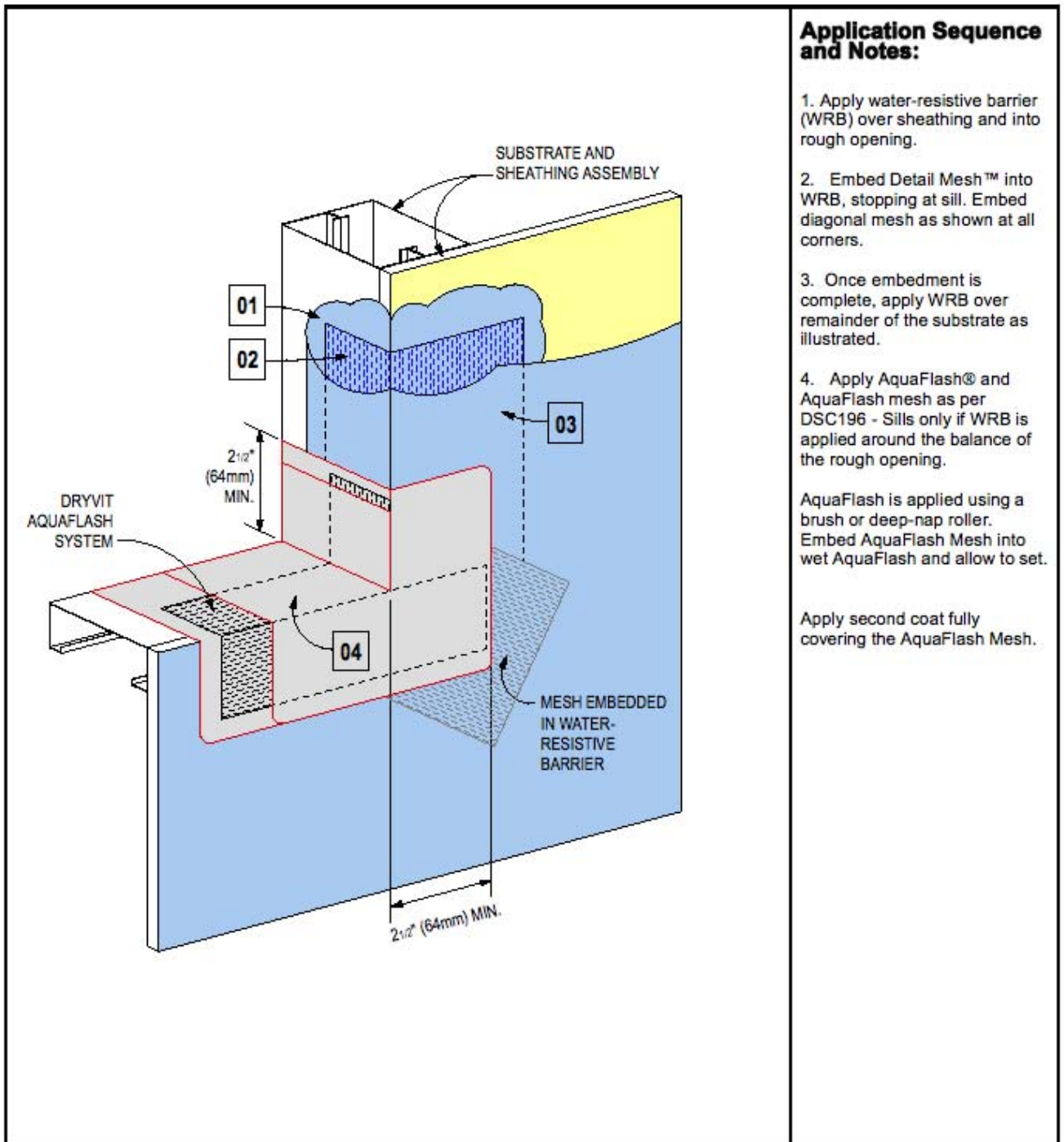

Figure 1

4.7. Application Sequencing and Notes

Note: Trade coordination and scheduled sequencing with project authority is required to ensure all rough openings are treated prior to mechanical unit installation. i.e.: door, window, venting, piping and including any other exterior penetrations.



Application Sequence and Notes:

1. Apply water-resistive barrier (WRB) over sheathing and into rough opening.
 2. Embed Detail Mesh™ into WRB, stopping at sill. Embed diagonal mesh as shown at all corners.
 3. Once embedment is complete, apply WRB over remainder of the substrate as illustrated.
 4. Apply AquaFlash® and AquaFlash mesh as per DSC196 - Sills only if WRB is applied around the balance of the rough opening.
- AquaFlash is applied using a brush or deep-nap roller. Embed AquaFlash Mesh into wet AquaFlash and allow to set.

Apply second coat fully covering the AquaFlash Mesh.

Figure 2: Protection of Rough Openings

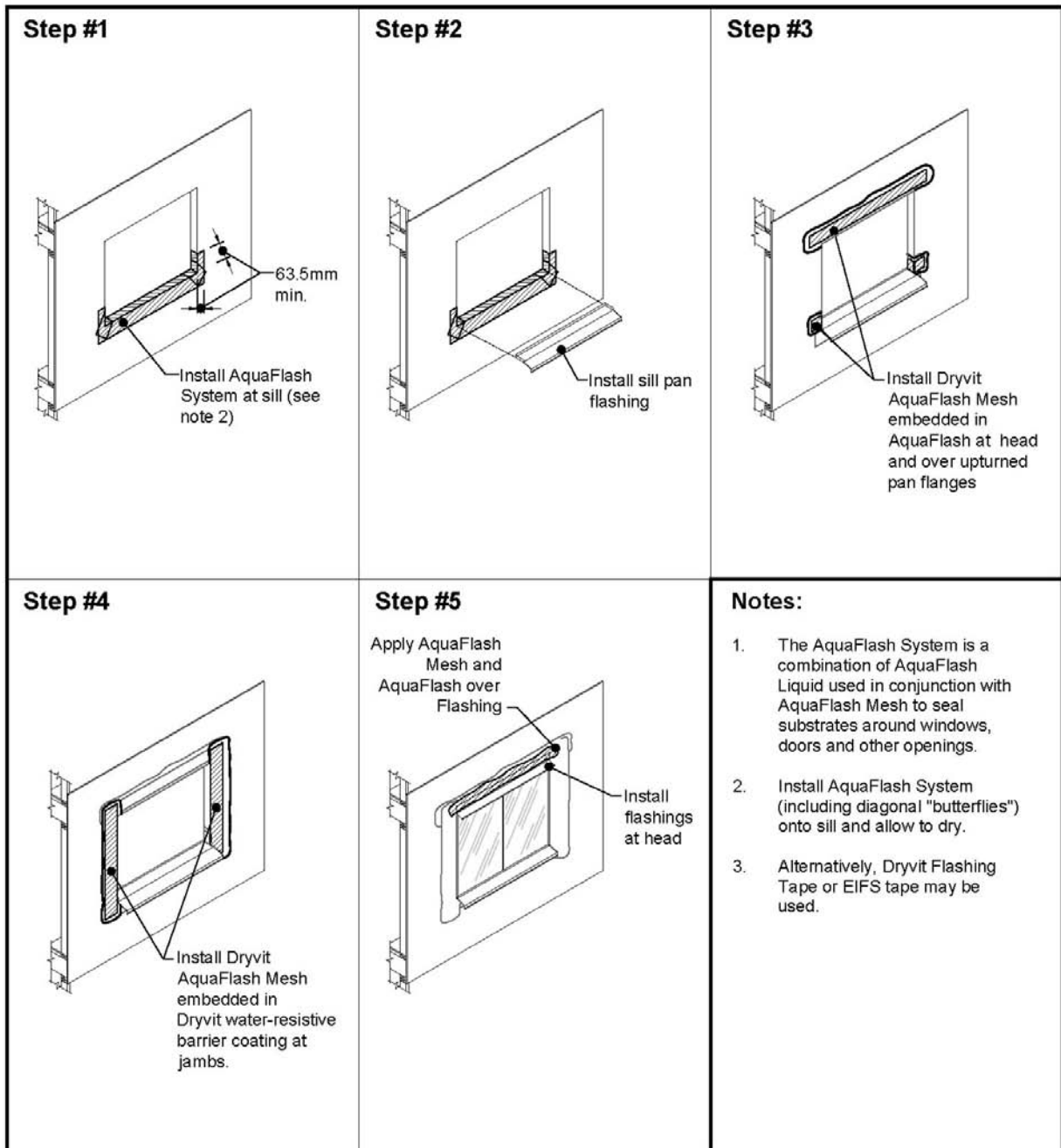

Figure 3: Rough opening and sill preparation – AquaFlash System

5. Substrate Expansion Joint Bridging Options

5.1. AquaFlash System Option

5.1.1. Surface Preparation

5.1.1.1. Apply only when air and surface temperatures are above 4 °C (40 °F).

5.1.1.2. The surface to receive AquaFlash System must be clean, dry, smooth and free of any condition that will hinder adhesion.

5.1.1.3. Clean loose dust or dirt from the surface by wiping with a clean, dry cloth or brush.

5.1.2. AquaFlash System Application

5.1.2.1. The width of the AquaFlash Mesh must overlap each side of the joint a minimum of 51 mm (2 in) – Figure 4.

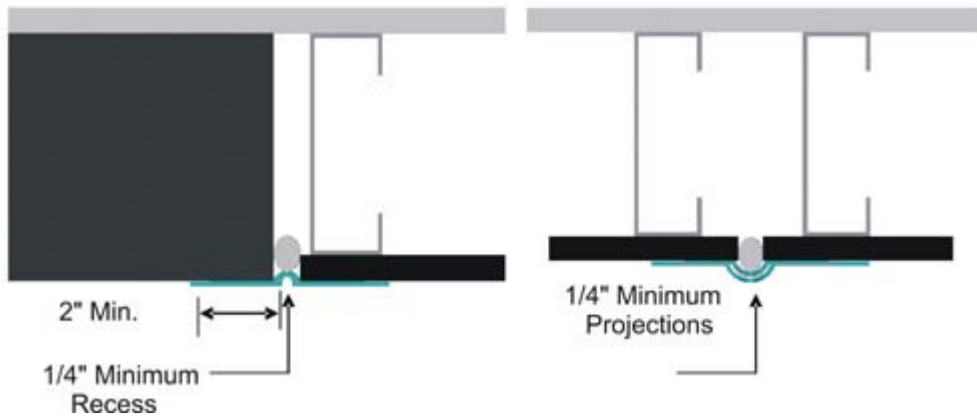

Figure 4

- 5.1.2.2. Clean the joint to allow for the installation of a backer material. Install a closed cell polyethylene backer rod sized a minimum of 50 % larger than the joint width. Install so that the backer rod is recessed or projects a minimum of 6.4 mm (1/4 in) from the wall surface.
- 5.1.2.3. Using a brush or 19 mm (3/4 in) nap roller, apply a liberal coat of AquaFlash liquid material to the backer rod and adjacent substrate surface to the width of the AquaFlash Mesh - Figure 5.

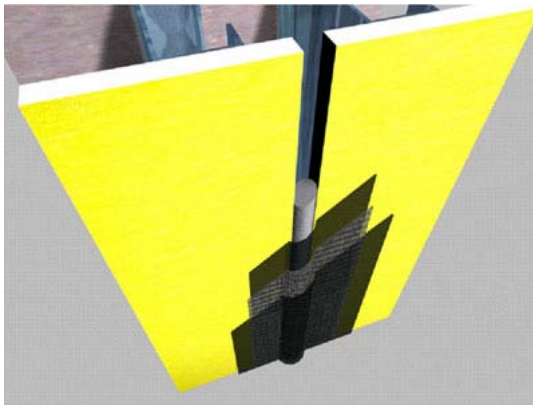

Figure 5

- 5.1.2.4. Immediately lay the AquaFlash Mesh into the wet material and brush smooth adding additional material to completely embed the mesh.
 - 5.1.2.5. Allow material to set for 15 minutes then apply a second liberal coat of AquaFlash liquid and smooth out to ensure a continuous film free of voids, pinholes, or other discontinuities.
- 5.2. Dryvit EIFS Tape and EIFS Tape Surface Conditioner Option
- *NOTE1: When Dryvit EIFS Tape is specified for substrate expansion joint bridging, the water-resistant barrier must be installed prior to preparing the joint (see Section 6).**
 - *NOTE2: Coordinate the Dryvit EIFS Tape application with the insulation board installation. Apply only enough Dryvit EIFS Tape that can be covered with the insulation board in the same work period.**
- 5.2.1. Surface Preparation
 - 5.2.1.1. Apply only when air and surface temperatures are above 4 °C (40 °F).
 - 5.2.1.2. The surface to receive Dryvit EIFS Tape Surface Conditioner and Dryvit EIFS Tape must be clean, dry, smooth and free of any condition that will hinder adhesion.
 - 5.2.1.3. Clean loose dust or dirt from the surface by wiping with a clean, dry cloth or brush.
 - 5.2.2. Dryvit EIFS Tape Surface Conditioner Application
 - 5.2.2.1. Pour the desired amount of surface conditioner into a clean container to prevent contamination.

- 5.2.2.2. Apply to the surfaces, which are to receive the Dryvit EIFS Tape, using a brush or roller. Sufficient surface conditioner should be applied to condition the surface to a dust free state suitable for the application of the Dryvit EIFS Tape. It should not be applied so heavily that it puddles or runs. Application of excess material will not improve adhesion but will extend the drying time.
- 5.2.2.3. Allow to dry until the surface is slightly tacky. Low temperatures and high humidity conditions may require longer drying times. Conditioning should be limited to areas that can be covered with Dryvit EIFS Tape within the same day.
- 5.2.3. Position the Dryvit EIFS Tape so that it is centered over the joint. Adhere to one side of the joint, and then adhere the adjacent side. Allow enough slack in the tape to account for any joint movement.

6. Air/Water-Resistive Barrier Application

6.1. Backstop NT

6.1.1. Substrate Check

- 6.1.1.1. Ensure that the substrate is of a type approved in the Backstop NT - Texture Specification DSC176 and Outsulation MD System Specifications DSC168NC.
- 6.1.1.2. Ensure that ambient and surface temperatures are minimum 4 °C (40 °F) and rising.
- 6.1.1.3. Ensure that the substrate is dry.
- 6.1.1.4. The substrate is flat within 6 mm (1/4 in) in a 1.2 m (4 ft) radius.
- 6.1.1.5. Ensure that sheathing gaps do not exceed 6 mm (1/4 in). Larger gaps must be corrected by replacing the sheathing material.
- 6.1.1.6. Notify the General Contractor and/or Architect and/or Owner of all discrepancies. Do not proceed with work until discrepancies have been corrected.

6.1.2. Surface Preparation

- 6.1.2.1. The substrate shall be free of foreign materials such as oil, dust, dirt, paint, efflorescence, wax, water repellents, moisture, frost and any other surface contaminants that may inhibit adhesion.
- 6.1.2.2. CMU mortar joints shall be struck flush, tooled mortar joints and heavily textured CMU (**not split faced**) or poured in place concrete shall be "skim coated" with Genesis when using Backstop NT - Texture or Airsulation.

6.1.3. Backstop NT - Texture Application

- 6.1.3.1. General: Backstop NT - Texture can be applied by trowel, roller, or spray equipment over the approved substrates. Backstop NT - Texture shall be applied at the recommended coverage rate at a wet film thickness of minimum 0.3 mm (12 mils) approximately the aggregate size and achieve a minimum dry film thickness of approximately 4 mils at all areas.
- 6.1.3.2. Highly porous surfaces may require more material. If test area shows that adequate coverage cannot be achieved with two coats surface area should be skimmed using Genesis material.
- 6.1.3.3. Trowel Application
 - 6.1.3.3.(1) Apply a strip of Scrim Tape over all sheathing joints and inside and outside corners. Mix the material as described above and, using a stainless steel trowel, apply a layer of Backstop NT - Texture over the Scrim Tape and spot all fastener heads, knots or voids. Allow to dry for a minimum of 1 hour or until dry to the touch. When using Backstop NT with AquaFlash Mesh embed mesh at all sheathing joints as noted for Scrim tape and cover.
 - 6.1.3.3.(2) Using a stainless steel trowel, apply a continuous coating of Backstop NT - Texture material onto the entire sheathing surface. The material should be applied at a smooth, uniform, continuous film approximately equal to the thickness of the aggregate.
- 6.1.3.4. Spray Application
 - 6.1.3.4.(1) Apply a strip of Scrim Tape over all sheathing joints and inside and outside corners. Mix the material as described above and, using a stainless steel trowel, apply a layer of Backstop NT - Texture over the Scrim Tape and spot all fastener heads. Allow to dry for a minimum of 1 hour or until dry to the touch. When using Backstop NT with AquaFlash Mesh embed mesh at all sheathing joints as noted for Scrim tape and cover.

- 6.1.3.4.(2) Using a hand held hopper gun, or other suitable spray equipment; spray a layer of Backstop NT – Texture onto the wall surface. Using a coarse, open-cell foam roller cover, with a 10 mm (3/8 in) foam nap, roll the material to create a smooth continuous film. NOTE: If the roller pulls material back out of the sheathing joints, it indicates that the joint material is not sufficiently dry.
 - 6.1.3.4.(3) While the Backstop NT - Texture is still wet, using a trowel or spatula, smooth out the Backstop NT - Texture around all window and door perimeters, and other areas that will later receive Dryvit Transition membrane
 - 6.1.3.4.(4) The Backstop NT - Texture material should be applied in a uniform, continuous film at the recommended coverage rate. NOTE: Substrates with a surface texture, or high porosity, will require more material.
 - 6.1.3.5. Prior to proceeding, check the wall to ensure that the Backstop NT - Texture is continuous and spot any visible voids with additional Backstop NT - Texture material.
 - 6.1.3.6. For areas where the secondary barrier is required to lap onto flashing or other material, it is recommended that the AquaFlash System be used to achieve the transition.
 - 6.1.3.7. Under normal conditions the wall will be ready to receive EIFS Tape or AquaFlash (when necessary) and adhesively applied EPS insulation after a minimum 4-hour drying period. As with all products that dry by evaporation, the drying rate will depend on the environmental conditions and porosity of the substrate. Cool damp weather will require longer drying times.
- 6.2. Airsulation (Note: Airsulation is not for use over wood sheathings)
- 6.2.1. Substrate Check
 - 6.2.1.1. Ensure that the substrate is of a type approved in the Airsulation Data Sheet DSC045 and Outsulation MD System Specifications DSC168NC.
 - 6.2.1.2. Ensure that ambient air and surface temperature is greater than 4 °C and remain so for at least 48 hours.
 - 6.2.1.3. Ensure that the substrate is dry and is flat within 6 mm (1/4 in) in a 1.2 m (4 ft) radius.
 - 6.2.1.4. Ensure that sheathing gaps do not exceed 6 mm (1/4 in). Larger gaps must be corrected by replacing the sheathing material.
 - 6.2.1.5. Notify the General Contractor and/or Architect and/or Owner of all discrepancies. Do not proceed with work until discrepancies have been corrected.
 - 6.2.2. Surface Preparation
 - 6.2.2.1. Airsulation is intended for use with Dryvit EIFS. All substrates shall not vary in plane more than $\pm 1/8$ " in a 4 ft. radius. The surface shall be free of contaminants, oil, or grease that could affect the membrane during or subsequent to application. Since Airsulation is a liquid, it is not intended to span cracks larger than 1.5 mm (1/16") nor should it be used as an expansion and control jointing material. Further, it requires that smashed blocks or gypsum board be repaired prior to application of the product.
 - 6.2.3. Airsulation Application
 - 6.2.3.1. Use a stainless steel or plastic trowel, to apply Airsulation. It also can be spray applied, whereby a minimum of 3200 psi and a 0.025 tip is recommended.
 - 6.2.3.2. Airsulation should be applied to a wet firm thickness of 70 mils in order to achieve the desired dry film thickness of 35 mils. Since Airsulation is translucent when dry, areas of lesser thickness will appear as light spots and will be easily visible to the eye from a distance.
 - 6.2.3.3. It is recommended that the above film thickness be achieved using the 2 coat method. Allow the 1st coat to harden prior to applying the 2nd coat.
 - 6.2.4. Prior to proceeding, check the wall to ensure that the Airsulation is continuous and spot any visible voids with additional Airsulation material.
 - 6.2.5. For areas where the secondary barrier is required to lap onto flashing or other material, it is recommended that Transition Membrane be used to achieve the transition.
 - 6.2.6. Under normal conditions the wall will be ready to receive Flashing Tape (when necessary) and adhesively applied EPS insulation after a minimum 4-hour drying period. As with all products that dry by evaporation, the drying rate will depend on the environmental conditions and porosity of the substrate. Cool damp weather will require longer drying time.

6.3. Dryflex (Note: Dryflex is not for use over wood sheathings)

6.3.1. Substrate Check

- 6.3.1.1. Ensure that the substrate is of a type approved in the Dryflex Data Sheet DSC430 and Outsulation MD System Specifications DSC168NC.
- 6.3.1.2. Ensure that ambient air and surface temperatures is greater than 4 °C and remain so for at least 24 hours.
- 6.3.1.3. Ensure that the substrate is dry and is flat within 6 mm (1/4 in) in a 1.2 m (4 ft) radius.
- 6.3.1.4. Ensure that sheathing gaps do not exceed 6 mm (1/4 in). Larger gaps must be corrected by replacing the sheathing material.
- 6.3.1.5. Notify the General Contractor and/or Architect and/or Owner of all discrepancies. Do not proceed with work until discrepancies have been corrected.

6.3.2. Surface Preparation

- 6.3.2.1. Surfaces must not be below 4 °C (40 °F) or painted and must be clean, dry, structurally sound and free of efflorescence, grease, oil, form release agents and curing compounds.

6.3.3. Dryflex Application

- 6.3.3.1. Using a stainless steel trowel or proper spray equipment, apply the Dryflex mixture to a uniform thickness of at least 3.2 mm (1/8") thick. A second coat may be necessary to seal the substrate.

- 6.3.4. Prior to proceeding, check the wall to ensure that the Dryflex is continuous and spot any visible voids with additional Dryflex material.

- 6.3.5. For areas where the secondary barrier is required to lap onto flashing or other material, it is recommended that Transition Membrane be used to achieve the transition.

- 6.3.6. Under normal conditions the wall will be ready to receive Flashing Tape (when necessary) and adhesively applied EPS insulation after a minimum 4-hour drying period. As with all products that dry by evaporation, the drying rate will depend on the environmental conditions and porosity of the substrate. Cool damp weather will require longer drying times.

7. Installation of Dryvit Starter Strip, Dryvit Vent Assembly™, Dryvit Vent Track™ Dryvit Track and Dryvit AquaDuct

7.1. Preparation

- 7.1.1. The Dryvit Vent Assembly with Dryvit Starter Strip, Dryvit Vent Track or Dryvit AquaDuct are required along the base of all system terminations such as base of walls and tops of horizontal expansion joints, windows and other openings.

- 7.1.1.1. Provide a permanent or temporary support for the Dryvit Starter Strip and Dryvit Vent Assembly and mark the location of the vent assembly along the base of the wall. Vent assemblies should be spaced every 3 m (10 ft) along the base of the wall to match the slot locations in the Dryvit Vent Track. The Dryvit AquaDuct shall continue onto the Vent Assembly and terminate at the Vent junction. **NOTE: Holes, created by fasteners used for temporary supports that penetrate the Backstop NT air/water-resistive barrier, AquaFlash System, or flashing tape, must be sealed with additional Backstop NT mixture, AquaFlash System, or flashing tape prior to adhering the insulation board.**

- 7.1.2. The Dryvit Starter Strip and Dryvit Track or the Dryvit AquaDuct are required at the heads of all openings.

- 7.1.2.1. Because insulation board joints cannot align with corners of openings, first cut L-shaped pieces of starter strip for the corners of the opening. Then measure and cut the Dryvit Starter Strip to the proper length to fit between the corner pieces over the opening.

- 7.1.2.2. Dryvit Track option: Measure and cut the Dryvit Track so that it extends beyond the edges of the opening to the closest vertical groove in the insulation board. Refer to Dryvit Outsulation MD System Installation Details, DSC167NC.

- 7.1.2.3. Dryvit AquaDuct option: Install the Dryvit AquaDuct continuously so that it extends beyond the edges of the opening to the closest vertical groove in the insulation board. Refer to Dryvit Outsulation MD System Installation Details, DSC167NC.

7.2. Installation

- 7.2.1. Begin installation from a permanent or temporary support.

- 7.2.2. Mix the Dryvit adhesive in accordance with Section 3.3. **WARNING: Do not apply the Dryvit materials in the rain. The air/water-resistive barrier surface must be clean and dry prior to adhering the insulation board.**

- 7.2.3. Cut the Detail Mesh to a working length.
- 7.2.4. Apply a ribbon of adhesive mixture on the substrate and position the Detail Mesh in the wet mixture allowing for a 64 mm (2 ½ in) minimum overlap onto the face of the starter strip and vent assembly. Keep the mesh, which is not embedded, clean.
- 7.2.5. Apply the adhesive mixture to the backside of the Dryvit Starter Strip and Dryvit Vent Assembly using a ribbon and dab pattern, and position on the wall. Press gently and slide into position applying uniform pressure to ensure full contact and high initial grab.
- 7.2.6. Using a margin trowel, remove any adhesive from the edges of the insulation boards that will abut other insulation boards. **CAUTION: Do not allow adhesive to remain in board joints. Ensure that the insulation board joints are abutted tightly and are level and flush.**
- 7.2.7. Dryvit Tack option: Install the Dryvit Vent Track and Dryvit Track by applying a continuous horizontal bead of Dryvit's AP Adhesive on the wall side of the vertical nailing flange of the track and position over the Dryvit Starter Strip. When installing the Dryvit Vent Track the cut out (slot) must be located directly above the Dryvit Vent Assembly. Press firmly against the substrate to ensure firm and continuous contact between the adhesive and the wall surface. **NOTE: It is recommended that the surface of the Drainage Track be lightly sanded to improve adhesion of Backstop NT or AquaFlash.**
- 7.2.8. Place a continuous bead of AP Adhesive where pieces of track abut each other, to provide a seal.
- 7.2.9. Install the AquaFlash System, Backstop NT and Grid Tape or Flashing Tape on the flange of the Dryvit Vent Track and the adjacent wall in order to ensure water-tightness at the flange/wall interface. See Section 4 for proper application.
- 7.2.10. Dryvit AquaDuct option: Install the Dryvit AquaDuct by applying a liberal coat of AquaFlash, using an appropriately sized paintbrush, to the topside horizontal chamfer of the Dryvit Starter Strip. Continue to apply a liberal amount of AquaFlash so as to coat the entire chamfered edge of the Dryvit Starter Strip with a uniform film lapping upwards onto the WRB surface a minimum of 75mm (3 in). Immediately imbed 100 mm (4") AquaFlash Mesh into the freshly applied AquaFlash ensuring the AquaFlash Mesh is installed the full height of the chamfer with the remainder lapping onto the wall. Once dry to the touch, apply a second coat of AquaFlash over the entire meshed area creating a uniform film thickness. **Ensure that the Dryvit AquaDuct is installed continuously (without termination or interruption) until an immediate junction is made with the Vent component of the Dryvit Vent Assembly.**

8. Installation of Insulation Board and Closure Blocks

8.1. Inspection of the Insulation Board

- 8.1.1. Prior to installing the insulation board and closure blocks, it shall be checked to ensure that:
 - 8.1.1.1. It is shipped in a clear polyethylene bag bearing the Dryvit name. In addition, the lot number of the insulation board shall be visible on the outside of the bag. Insulation board shall be obtained from Dryvit Systems Canada or its authorized distributors, and made exclusively by manufacturers listed by Dryvit Systems Canada
 - 8.1.1.2. The insulation board measures a maximum of 0.6 m (2 ft) by 1.2 m (4 ft) with a minimum thickness of 19 mm (3/4 in).
 - 8.1.1.3. The insulation board closure blocks measure between 152 mm (6 in) and 305 mm (12 in) in width by 1.2 m (4 ft) in length. The minimum thickness is 51 mm (2 in).
 - 8.1.1.4. The insulation board meets the following tolerances:
 - 8.1.1.4.(1) Length: Plus or minus 1.6 mm (1/16 in).
 - 8.1.1.4.(2) Width: Plus or minus 1.6 mm (1/16 in).
 - 8.1.1.4.(3) Thickness: Plus or minus 1.6 mm (1/16 in) for boards greater than 25 mm (1 in), plus 1.6 mm (1/16 in) minus 0 for boards less than or equal to 25 mm (1 in).
 - 8.1.1.4.(4) Squareness: Shall not deviate from square by more than 0.8 mm (1/32 in) in 305 mm (12 in) of total length or width.
 - 8.1.1.4.(5) Edge Trueness: Shall not deviate more than 0.8 mm (1/32 in) in 305 mm (12 in).
 - 8.1.1.4.(6) Face Flatness: Shall not exhibit any bowing of more than 0.8 mm (1/32 in) in the length.

WARNING: Any insulation board, closure block or starter strip not meeting the above requirements should be rejected and not installed.

- 8.1.1.5. The backside of the insulation board contains vertical grooves as shown in the Dryvit Outsulation MD System Installation Details, DSC167NC.
 - 8.1.1.6. The surface of the water-resistive barrier (WRB) is uniform in thickness, continuous, clean, dry and free of any foreign materials that will affect adhesion of the insulation board.
- 8.2. Methods of Applying the Dryvit Adhesive
- 8.2.1. Mix the Dryvit adhesive in accordance with Section 3.3.
 - 8.2.1.1. Cementitious Adhesive
 - 8.2.1.1.(1) Notched Trowel Method
 - 8.2.1.1.(1)(a) With a notched trowel, 12.7 mm (1/2 in) wide, 12.7 mm (1/2 in) deep notches spaced 50.8 mm (2 in) apart, apply the adhesive mixture to the backside of the insulation board. Holding the trowel at a 45° angle, apply firm pressure to the insulation board in order to scrape the excess adhesive from between the adhesive beads.
NOTE: Apply the adhesive so that the ribbons run vertically when the insulation board is placed on the wall.
 - 8.2.1.1.(2) Ribbon and Dab Method
NOTE: The ribbon and dab method of applying the adhesive mixture is only acceptable when applying Dryvit Starter Strips, Vent Assemblies.
 - 8.2.1.1.(3) Push Box Method
 - 8.2.1.1.(3)(a) A push box may also be used to install the adhesive mixture on the insulation board. Contact Dryvit Systems Canada for complete details for construction of a push box. **NOTE: Apply the adhesive so that the ribbons run vertically when the insulation board is placed on the wall.**
 - 8.2.1.2. Non-cementitious Adhesive
 - 8.2.1.2.(1) AP Adhesive - recommended for use in limited areas only, such as metal surfaces, including steel lintels, metal flashing, etc.
 - 8.2.1.2.(1)(a) Cut the smallest opening possible in spout (just large enough so adhesive can flow easily when gunned). It is intended to be applied in thin beads [approximately 9.5 mm (3/8 in)].
- 8.3. Insulation Board Installation
 - 8.3.1. With a notched trowel [12.7 mm (1/2 in) wide, 12.7 mm (1/2 in) deep notches spaced a maximum 51 mm (2 in) apart], apply the adhesive mixture to the backside of the insulation board being careful not to allow the adhesive mixture in the grooves of the board. Apply the adhesive so that the ribbons are running vertically.
 - 8.3.2. Beginning at the base of the wall (above the Dryvit Starter Strip), install the insulation boards with their long edges oriented horizontally. Locate the insulation boards so that joints are offset from the sheathing board joints a minimum of 203 mm (8 in) in both vertical and horizontal directions.
 - 8.3.3. Position the insulation board horizontally on the substrate. Press the board gently to the substrate and slide it into position. Apply firm pressure over the entire surface of the insulation board to ensure uniform contact and high initial grab.
 - 8.3.4. Using a margin trowel, clean the insulation board edges of any adhesive mixture. Ensure that the insulation board joints are butted tightly and faces are level and flush. **CAUTION: Do not allow adhesive to remain in board joints.**
 - 8.3.5. Install subsequent rows of insulation board in a running bond pattern (vertical joints staggered) as shown in Figure 6. Please note the alignment of vertical grooves is not required.

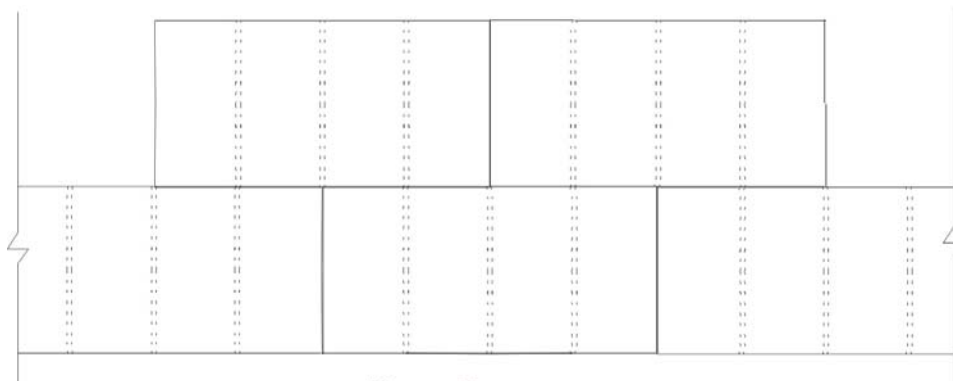

Figure 6

- 8.3.6. With factory edges exposed, stagger vertical joints at inside and outside corners. Make sure the corners are straight and plumb.
- 8.3.7. To ensure an overall flat surface, tamp the insulation board surface with a board that overlaps two to four rows of insulation.
- 8.3.8. Tops of walls, sills of continuous windows and other horizontal system terminations are terminated using 152 mm x 305 mm x 1.2 m (6 in x 12 in x 48 in) closure blocks. These are adhered to Backstop NT using a ribbon and dab adhesive pattern as shown in the Figure 7.

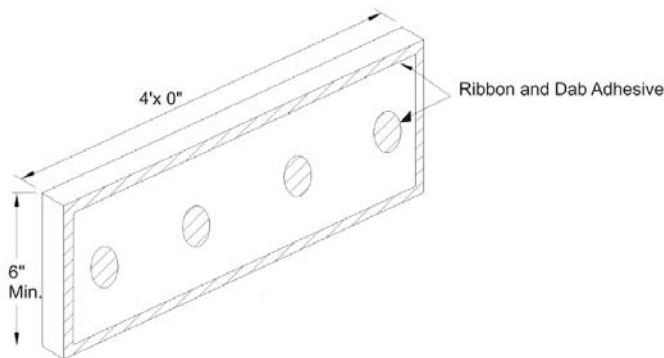

Figure 7

- 8.3.9. If for any reason the insulation board joints are not butted tightly, slivers of insulation board must be installed to fill any gaps. **ALL GAPS GREATER THAN 1.6 mm (1/16 in) MUST BE SLIVERED. Tip: In order to create a tight fit, it is recommended that a wider joint be cut with a hot groover or similar tool to allow for a more precise fitting sliver. Do not install adhesive on sliver edges.**
- 8.3.10. Windows, Doors, Mechanical Equipment and all Wall Penetrations
 - 8.3.10.1. At openings, align the insulation boards so that the edges (vertical and horizontal joints) do not coincide with the corners of the opening as illustrated in Figure 8 (refer to Dryvit Outsulation MD System Installation Details, DSC167NC).

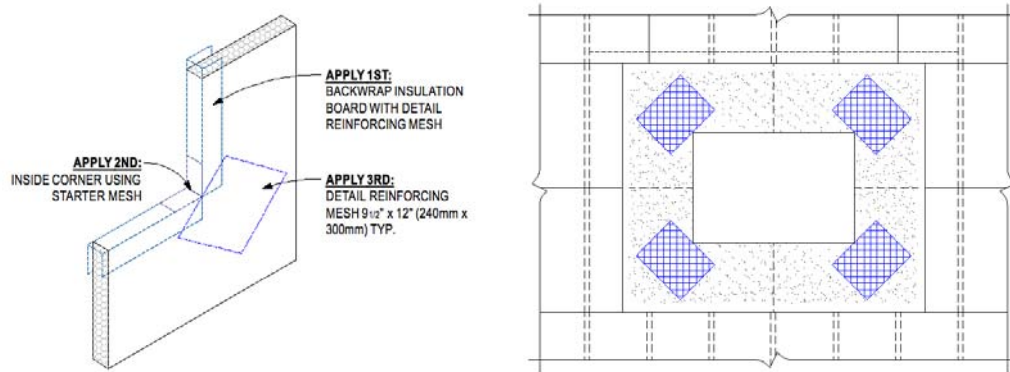

Figure 8

- 8.3.10.2. Hold the insulation board back from the window/door frame or mechanical equipment to allow for differential movement, proper system edge preparation, and sealant installation as shown in the Dryvit Outsulation MD System Installation Details, DSC167NC.
- 8.3.11. Expansion Joints
 - 8.3.11.1. Attach Detail Mesh on each side of the expansion joint by stapling or applying a ribbon of adhesive mixture on the substrate and embedding the Detail Mesh into the wet mixture.
 - 8.3.11.2. Position the Detail Mesh so that a minimum of 64 mm (2 1/2 in) will extend onto the face of the insulation board. Keep the mesh, which is not embedded, clean.
 - 8.3.11.3. When abutting dissimilar materials, leave a minimum 19 mm (3/4 in) separation between the insulation board and abutting material to allow for differential movement, proper system edge preparation and sealant installation.
 - 8.3.11.4. When the Outsulation MD System is installed at a substrate transition, leave a minimum 19 mm (3/4 in) separation between the insulation boards to allow for differential movement, proper system edge preparation and sealant installation.
- 8.3.12. **IMPORTANT:** Once the insulation board and Detail Mesh are in place, wait a minimum of 24 hours prior to working on the surface of the insulation board to prevent any movement which may weaken the bond of the adhesive mixture to the substrate. **NOTE: Be sure to protect the installed insulation board from rain, freezing or inclement weather for a period of 24 hours.**
- 8.3.13. Any irregularities in the insulation board surface must be sanded flat. Sanding is accomplished with a light circular motion. **The entire wall area must be sanded.** Use grade 20 grit sandpaper or coarser, in conjunction with hand, electric or air rasps. Use OSHA required masks to protect against inhaling EPS dust. **NOTE: Do not sand parallel to the insulation board joints. CAUTION: The contractor shall take precautions to contain EPS dust from rasping operation in accordance with contract documents. Use of vacuum rasps are recommended to minimize introduction of EPS dust into the environment.**
- 8.3.14. Remove all loose pieces of insulation board and dust from the sanding operation using a brush, broom, or compressed air. Use OSHA required masks to protect against inhaling EPS dust.
- 8.3.15. All Detail Mesh that was previously installed for back wrapping the insulation board shall be embedded in the base material mixture at this time.
 - 8.3.15.1. With a stainless steel trowel, apply the base material mixture to the face (and edge if not previously coated) of the insulation board and embed the Detail Mesh in the wet mixture.
- 8.3.16. Aesthetic Reveals

NOTE: Insulation board thickness may need to be increased to accommodate reveals and maintain minimum 19 mm (3/4 in) thickness of EPS at all locations.

 - 8.3.16.1. To install an aesthetic reveal, snap a straight line using a chalk line to mark the position.
 - 8.3.16.2. Position a straight edge such as a steel stud or track against the insulation board in the proper location to guide the appropriate cutting tool (router, hot knife, or hot groover).
 - 8.3.16.3. Use Detail Mesh to ensure continuity of reinforcing mesh through aesthetic reveals continuing a minimum of 63.5mm (2 1/2 in) on each side of the reveal.
 - 8.3.16.3.(1) Apply the base material mixture in the reveal and on the adjacent insulation board surfaces.
 - 8.3.16.3.(2) Embed the Detail Mesh into base coat mixture on one side of the reveal only.

- 8.3.16.3.(3) Use a sled or special tool configured to the profile of the reveal. Embed the Detail Mesh into the base coat mixture through the reveal being careful not to cut the mesh.
 - 8.3.16.3.(4) Embed the Detail Mesh into the base coat mixture on the other side of the reveal. Ensure that the mesh is fully embedded and that all excess material is removed from the reveal.
 - 8.3.16.3.(5) Using a damp brush, smooth out any irregularities in the base coat. **CAUTION: If the mesh is cut in the reveal, a new piece of mesh must be installed over the cut.**
- 8.3.17. Where Corner Mesh is specified for additional impact resistance at outside corners, the Corner Mesh shall be embedded in the base coat mixture and allowed to set prior to installing the overall reinforced base coat over the face of the wall.
- 8.3.18. Corners of all openings such as windows, doors, mechanical equipment and all penetrations shall be reinforced with Detail Mesh placed diagonally to the opening as illustrated in Figure 8 previously.

9. Installation of Reinforcing Mesh and Base Coat

9.1. General

9.1.1. **Do not apply the Dryvit materials in the rain. The insulation board must be dry prior to applying the base coat material.**

9.1.2. Prior to installing the reinforced base coat, inspect the surface of the insulation board for:

9.1.2.1. Flatness: Use a minimum 2.4 m (8 ft) straight edge. Sand any high areas and out-of-plane board joints flat, as described in Section 8.3.13 and 14. **CAUTION: Do not build up low areas with base coat mixture to form a flat surface.**

9.1.2.2. Damage and foreign materials: correct deficiencies as necessary.

9.1.2.3. Surface degradation due to weathering or UV, visible as discoloration. Sand affected areas to remove deterioration while maintaining the flatness of the surface.

9.2. Mix the base coat material as described in Section 3.3 and 3.4.

9.3. Prior to installing the reinforcing mesh, it should be inspected to ensure that it has been furnished by Dryvit Systems Canada

9.3.1. Dryvit reinforcing mesh is available in the following widths and lengths:

9.3.1.1. Standard - 1.2 m x 45.7 m (48 in x 150 ft); 1.8 m x 45.7 m (72 in x 150 ft)

9.3.1.2. Standard Plus, and Intermediate - 1.2 m x 45.7 m (48 in x 150 ft)

9.3.1.3. Panzer 15 - 1.2 m x 22.9 m (48 in x 75 ft)

9.3.1.4. Panzer 20 - 1.2 m x 22.9 m (48 in x 75 ft)

9.3.1.5. Corner - 235 mm x 45.7 m (9 1/4 in x 150 ft)

9.3.1.6. Detail - 241 mm x 45.7 m (9 1/2 in x 150 ft)

9.4. Installation of Dryflex base coat in high exposure areas such as sloped surfaces, window sills, etc.

9.4.1. Using a stainless steel trowel, apply the Dryflex mixture on the surface of the insulation board in a uniform thickness of approximately 2.4 mm (3/32 in). Apply the Dryflex continuously over the sloped surface and continue minimum 152 mm (6 in) onto the vertical areas.

9.4.2. Immediately place the reinforcing mesh against the wet Dryflex mixture. With the curve of the mesh against the wall, trowel from the center to the edges, avoiding wrinkles, until the mesh is fully covered and not visible. The overall minimum base coat thickness shall be sufficient to **fully embed** the reinforcing mesh. The recommended method is to apply the base coat in two (2) passes. **NOTE: The reinforcing mesh can be continued across the transition from Dryflex base coat to standard base coat.**

9.4.3. Allow the Dryflex to cure a minimum of 24 hours or until dry.

9.5. Base Coat Application

9.5.1. Standard Base Coat (single layer of Standard, Standard Plus or Intermediate Reinforcing Mesh)

9.5.1.1. The base coat shall be applied such that the resulting overall minimum base coat thickness is sufficient to **fully embed** the reinforcing mesh. The recommended method is to apply the base coat in two (2) passes.

9.5.1.2. Double pass method (recommended)

9.5.1.2.(1) Using a stainless steel trowel, apply the base coat mixture on the entire surface of the insulation board to an area slightly larger than the width and length of a piece of reinforcing mesh, in a uniform thickness of 2.1 mm (1/12 in). **NOTE: The reinforcing mesh may be installed either vertically or horizontally.**

- 9.5.1.2.(2) Immediately place the reinforcing mesh against the wet base coat mixture. With the curve of the mesh against the wall, trowel from the center to the edges avoiding wrinkles, until the mesh is fully embedded and not visible. Trowel smooth to a uniform thickness slightly more than the thickness of the reinforcing mesh. **NOTE: The reinforcing mesh shall be continuous at corners and mesh edges lapped not less than 76.2mm (3 in). Do not lap the reinforcing mesh within 203.2 mm (8 in) of a corner. Tip: Corners and edges normally require light strokes with a small damp brush to smooth out irregularities.**
- 9.5.1.2.(3) Allow the base coat mixture to take up until firm to the touch. Trowel a second tight coat of the base coat mixture over the first coat to **fully cover** the reinforcing mesh – Figure 9. The result should be such that the reinforcing mesh is approximately centered within the base coat thickness. Do not allow the first pass to completely dry prior to the second pass application or an excessive amount of base coat mixture will be necessary to fully coat the wall surface.

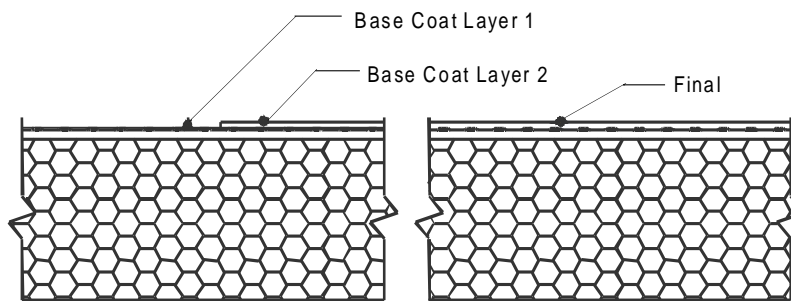

Figure 9

- 9.5.1.3. Single pass method (optional)
 - 9.5.1.3.(1) Using a stainless steel trowel, apply the base coat mixture on the entire surface of the insulation board to an area slightly larger than the width and length of a piece of reinforcing mesh, in a uniform thickness of 2.4 mm (3/32 in). **NOTE: The reinforcing mesh may be installed either vertically or horizontally.**
 - 9.5.1.3.(2) Immediately place the reinforcing mesh against the wet base coat mixture. With the curve of the mesh against the wall, trowel from the center to the edges avoiding wrinkles, until the mesh is fully embedded and not visible. Trowel smooth to a uniform thickness slightly more than the thickness of the reinforcing mesh. **NOTE: The reinforcing mesh shall be continuous at corners and mesh edges lapped not less than 76.2mm (3 in). Do not lap the reinforcing mesh within 203.2 mm (8 in) of a corner. Tip: Corners and edges normally require light strokes with a small damp brush to smooth out irregularities.**
- 9.5.1.4. Protect completed work from water penetration and runoff.
- 9.5.1.5. Allow the base coat to cure a minimum of 24 hours before proceeding with application of finish coat. Cool, damp conditions may require longer drying times. Do not apply finish to a wet or damp base coat.
- 9.5.2. Panzer Mesh Base Coat (Panzer 15 or Panzer 20 used in conjunction with Standard or Standard Plus Reinforcing Mesh). **Panzer Mesh is recommended for use at all ground floor locations and at high traffic areas. Refer to contract documents.**
 - 9.5.2.1. Using a stainless steel trowel, apply the base coat mixture on the entire surface of the insulation board to an area slightly larger than the width and length of a piece of reinforcing mesh, in a uniform thickness of approximately 3.2 mm (1/8 in).
 - 9.5.2.2. Immediately place the reinforcing mesh against the wet base coat mixture. With the curve of the mesh against the wall, trowel from the center to the edges avoiding wrinkles until the mesh is fully covered and not visible.
 - 9.5.2.3. Continue in the same manner until the entire area requiring Panzer Mesh is covered. **CAUTION: Do not lap the Panzer Mesh. Adjacent pieces are to be tightly butted.**
 - 9.5.2.4. Protect completed work from water penetration and runoff.
 - 9.5.2.5. Allow the Panzer base coat to cure a minimum of 24 hours prior to applying Dryvit's Standard or Standard Plus Reinforcing Mesh.
 - 9.5.2.6. Apply the second layer of reinforcing mesh in accordance with Section 9.5.1.3. Offset the edges of the Standard or Standard Plus Reinforcing Mesh from the edges of the Panzer

Mesh a minimum of 203.2 mm (8 in). **Tip: If Panzer Mesh is installed horizontally, we recommend the Standard or Standard Plus Mesh be installed vertically and vice versa.**

10. Sealant Joint Preparation

- 10.1. All Outsulation MD base coat surfaces which will be in contact with sealant must be coated with either Color Prime or Demandit.
 - 10.1.1. Mix Color Prime or Demandit in accordance with Section 3.5 and 3.8 respectively.
 - 10.1.2. Using a small brush, apply Color Prime or Demandit to the base coat surface that is to be in contact with the sealant and extending to the joint edge.
 - 10.1.3. Allow the Color Prime or Demandit to dry a minimum of 48 hours prior to applying the sealant. Cool damp weather may require longer drying times.
 - 10.1.4. Refer to sealant manufacturer's installation instructions for the proper application of the sealant.

11. Dryvit Primers

- 11.1. Prior to applying the Dryvit primers, the base coat shall have cured a minimum of 24 hours and shall be dry and hard. Cure time may be longer depending on environmental conditions. **NOTE: Refer to Product Data Sheets when applying over other materials.**
- 11.2. Inspect the base coat for any irregularities such as trowel marks, board lines, rough corners and edges, improper reinforcing mesh embedment as well as efflorescence. **NOTE: Correct all irregularities and remove all efflorescence prior to applying the Dryvit primer.**
- 11.3. Color Prime and Weatherprime
 - 11.3.1. Mix to a smooth homogeneous consistency in accordance with Section 3.5.
 - 11.3.2. Apply with a brush, roller, or airless spray equipment. Refer to Color Prime or Weatherprime Data Sheets, DSC410 or DSC436 respectively for complete instructions.
- 11.4. Primer with Sand
 - 11.4.1. Mix to a smooth homogeneous consistency in accordance with Section 3.5.
 - 11.4.2. Application with a roller is recommended. Refer to Primer with Sand Data Sheet, DSC477 for complete instructions.
- 11.5. Prymit
 - 11.5.1. Mix to a smooth homogeneous consistency in accordance with Section 3.5.
 - 11.5.2. Apply with a 6.4 mm to 9.5 mm (1/4 in to 3/8 in) nap roller or a wide nylon bristle brush.
 - 11.5.3. Apply a liberal coat of Prymit to the prepared glazed or painted surface. Allow to dry fully before installing the Outsulation MD System. Refer to Prymit Data Sheet, DSC424 for complete instructions.

12. Dryvit Finish

- 12.1. Prior to applying the Dryvit finish, the base coat shall have cured a minimum of 24 hours and shall be dry and hard. Cure time may be longer depending on environmental conditions.
- 12.2. Inspect the base coat for any irregularities such as trowel marks, board lines, rough corners and edges, improper reinforcing mesh embedment as well as efflorescence. **NOTE: Correct all irregularities and remove all efflorescence prior to applying the Dryvit finish.**
- 12.3. Application
 - 12.3.1. General
 - 12.3.1.1. Important: All Dryvit finishes must be installed continuously to a natural break such as corners, expansion joints, or tapeline. Mechanics must maintain a wet edge. Whenever possible, order enough material in a single batch to complete the project to avoid potential color variations from batch to batch. Sufficient personnel and scaffolding must be provided to continuously finish a distinct wall area or otherwise cold joints will result. Scaffolding must be spaced a minimum of 458 mm (18 in) from the wall to prevent staging lines. On hot windy days, the wall may be fogged with clean potable water to cool the wall and facilitate finish installation. As with other plaster materials, installation work should precede the sun. For example, work the shady or cool side of the building. If this is not possible, scaffold should be shaded with a tarp or nursery shade cloth. Do not introduce water to the finish material once it is installed on the wall. This will cause color variations. Each mechanic must use the same tool and hand motion and match the texture of the mechanics above, below and on each side. Use finish from a single batch number whenever possible.

- 12.3.1.2. Do not apply Dryvit materials in the rain. The base coat must be dry prior to applying the Dryvit finish or coatings.
- 12.3.1.3. Do not apply textured Dryvit finish material in sealant joints. Refer to Section 10 for proper sealant joint preparation.
- 12.3.2. Quarzputz, Quarzputz E, Sandblast, Weatherlastic Quarzputz
 - 12.3.2.1. Mix the Dryvit finish as described in Section 3.6.
 - 12.3.2.2. Using a clean stainless steel trowel, apply a coat of the Dryvit finish in a uniform thickness on the dry base coat. **NOTE: The Dryvit Quarzputz finish shall be applied and leveled to a uniform thickness no greater than the largest aggregate. The Sandblast finish is applied and leveled to a thickness of approximately 1 1/2 times the largest aggregate.**
 - 12.3.2.3. The texture is achieved by uniform hand motion and/or tool that produces the texture to match the approved sample. Each mechanic must use the same tool and hand motion to ensure that the texture achieved is uniform over the entire wall area.
- 12.3.3. Sandpebble, Sandpebble E, Sandpebble Fine, Sandpebble Fine E, Weatherlastic Sandpebble, Weatherlastic Sandpebble Fine
 - 12.3.3.1. Mix the Dryvit finish as described in Section 3.6.
 - 12.3.3.2. Using a clean, stainless steel trowel, apply an even coat of the finish to a thickness slightly thicker than the largest aggregate size.
 - 12.3.3.3. Pull across using a horizontal trowel motion to develop a uniform thickness no greater than the largest aggregate of the material.
 - 12.3.3.4. The texture is achieved by a uniform hand floating motion with a clean stainless steel trowel; wipe the trowel and wet it lightly. Apply light pressure in a circular motion.
- 12.3.4. Freestyle
 - 12.3.4.1. Mix the Dryvit finish as described in Section 3.6.
 - 12.3.4.2. Using a clean, stainless steel trowel, apply the Freestyle finish on the base coat in a thickness not greater than 1.6 mm (1/16 in). The texture is either pulled out of this base to a thickness of no greater than 6.4 mm (1/4 in) or the texture may be achieved by adding more Freestyle finish to the base coat using the same texturing motions that are used with other plaster materials, such as, a skip trowel finish. Numerous other aesthetically pleasing textures can be created to match approved samples. **NOTE: The maximum thickness of Freestyle finish texture shall not exceed 6.4 mm (1/4 in).**
- 12.3.5. Weatherlastic Adobe
 - 12.3.5.1. Using a brush, roller or airless spray equipment, apply a coat of color coordinated Color Prime (see Section 3.5 for mixing instructions) at the recommended coverage to the cured base coat and allow to dry.
 - 12.3.5.2. Mix the Weatherlastic Adobe finish material as described in Section 3.6.
 - 12.3.5.3. Using a stainless steel trowel, apply a coat of Weatherlastic Adobe approximately 1.6 mm (1/16 in) to the wall surface. Allow the Weatherlastic Adobe finish to take-up.
 - 12.3.5.4. Using a stainless steel trowel, apply a second coat of Weatherlastic Adobe to obtain the desired texture. **Tip: An atomizing spray bottle may be used to apply a mist of water to the surface in the finishing step.**
- 12.3.6. Ameristone
 - 12.3.6.1. Mix the Ameristone finish as described in Section 3.7.1.
 - 12.3.6.2. Apply Ameristone finish in accordance with Ameristone Application Instructions, DSC142.
- 12.3.7. Stone Mist
 - 12.3.7.1. Mix the Stone Mist finish as described in Section 3.7.2.
 - 12.3.7.2. Apply Stone Mist finish in accordance with Stone Mist Data Sheet, DSC420.
- 12.3.8. TerraNeo
 - 12.3.8.1. Mix the TerraNeo finish as described in Section 3.7.3.
 - 12.3.8.2. Apply TerraNeo finish in accordance with TerraNeo Data Sheet, DSC481.
- 12.3.9. Limestone
 - 12.3.9.1. Mix the Limestone finish as described in Section 3.7.4.
 - 12.3.9.2. Apply Limestone finish in accordance with Limestone Data Sheet, DSC472.
- 12.3.10. Custom Brick
 - 12.3.10.1. Refer to Dryvit Custom Brick Application Instructions, DSC154 and DSC214, for complete installation instructions.

13. Coatings and Sealers

13.1. Demandit and Weathercoat

- 13.1.1. Mix to a smooth homogeneous consistency in accordance with Section 3.8.1.
- 13.1.2. Apply with a brush, roller, or airless spray equipment.
- 13.1.3. When applying with a roller, a maximum 19 mm (3/4 in) nap, polyester or polyester blend with nylon or lambs wool, with beveled ends and a phenolic core is recommended. A 458 mm (18 in) wide roller frame with a 57 mm (2 1/4 in) inside diameter is also recommended.
- 13.1.4. Apply in one continuous coat, maintaining a wet edge as the application proceeds to a natural break. The roller cover must be kept fully loaded as the application proceeds. **CAUTION: Do not stretch out the application by rolling with a dry roller. The last leveling roller strokes should always be in the same direction. Do not cut in around openings prior to overall application, but rather, do the cut-in work as the application proceeds.**
- 13.1.5. Do not allow Demandit or Weathercoat to dry on roller covers. Roller covers with dried coating do not apply the coating evenly.
- 13.1.6. Changing color requires the application of two coats.

13.2. Revyvit

- 13.2.1. Mix the Revyvit to a smooth homogeneous consistency in accordance with Section 3.8.1.
- 13.2.2. Apply the Revyvit with a brush or 12.7 mm – 15.9 mm (1/2 in - 5/8 in) nap roller.
- 13.2.3. Roll or brush in multiple directions and then lightly finish in one direction to ensure that no lap marks remain.
- 13.2.4. A second coat may be required for heavy textured surfaces or when there is a contrast of colors. Apply the second coat as described in paragraph XI.B.2 and 3 above. **CAUTION: Do not attempt to apply Revyvit in one heavy coat. Two coats are recommended. Apply the second coat only after the first coat is completely dry. Important: Texture changes will exist after Revyvit is applied over existing Dryvit finishes. The degree of change is a function of the thickness and the number of coats of Revyvit.**

13.3. Weatherlastic Smooth

- 13.3.1. Mix the Weatherlastic Smooth to a smooth, homogeneous consistency in accordance with Section 3.8.1.
- 13.3.2. Apply a minimum 11 mils dry film thickness (22 mils wet film thickness). This is achieved by applying the Weatherlastic Smooth in two (2) 11 mil wet coats. Under average drying conditions, 21 °C (70 °F), 50 % RH, two (2) hours drying time between coats should be adequate.
- 13.3.3. For cutting-in and trim, a nylon bristle brush is recommended.
- 13.3.4. Roller Application
 - 13.3.4.1. A minimum 254 mm (10 in) roller cover with a 32 mm - 38 mm (1 1/4 in - 1 1/2 in) nap is recommended
 - 13.3.4.2. Completely saturate the roller cover and keep the roller loaded with coating to avoid foaming. Do not dry roll or over-roll as this will cause excessive entrapment of air within the coating.
 - 13.3.4.3. A second coat is applied in a similar manner after the first coat has adequately dried.
- 13.3.5. Spray Application
 - 13.3.5.1. Application by airless spray equipment or mastic pump and gun allows application of coating at total required application rate with a minimum of stipple or thickness variations.
 - 13.3.5.2. Equipment should have the capacity to pump 7.6 L (2 gal) of coating per minute.
 - 13.3.5.3. Material hose should be minimum 12.7 mm (1/2 in) inside diameter for spraying coating through more than a 15 m (50 ft) length. Minimum bursting of 3600 N (800 lbs) is recommended. **Tip: Orifice sizes of 0.53 mm - 0.81 mm (0.021 in - 0.032 in) will be required depending on equipment used.**
 - 13.3.5.4. Cross apply coating holding spray gun perpendicular to, and approximately 1 m (3 ft) from the wall surface. Avoid excessive material build-up by holding spray gun away from the wall when pulling the trigger, then bringing gun across area to be coated. Maintain a wet edge and avoid starting and stopping in the middle of the wall. Do not attempt to overreach spray pattern as this may result in appearance of irregular spray pattern. Place scaffolding and equipment to facilitate quick application without numerous interruptions.
 - 13.3.5.5. A 10 % loss from overspray should be anticipated.
 - 13.3.5.6. Backrolling sprayed areas is recommended to control pinholing on spray applications over porous surfaces.
- 13.3.6. Tuscan Glaze

- 13.3.6.1. Mix Tuscan Glaze to a smooth homogenous consistency in accordance with Section 3.8.2. Continuously agitate throughout application to ensure color consistency.
 - 13.3.6.2. Tuscan Glaze is best applied on large areas using a Hudson-type sprayer or airless spray equipment. For smaller areas, Tuscan Glaze is best applied with a paint pad or, depending on the desired results, a roller, paintbrush or sponge. Job site mock-ups are required and should represent the actual job site application techniques.
 - 13.3.6.3. Apply Tuscan Glaze evenly in light strokes. If sagging or running occurs, use a sponge or paint pad to correct immediately. Watch for brush or roller lines. If brush or roller lines appear, use a damp sponge, a paint pad or rag to make them disappear before the Tuscan Glaze starts to dry. The wall may be blotted with a camelback sponge to achieve the desired mottled appearance. Check walls throughout the application to insure that uniformity and the desired appearance is achieved.
- 13.3.7. SealClear
- 13.3.7.1. Mix SealClear to a smooth, homogeneous consistency in accordance with Section 3.8.3.
 - 13.3.7.2. For application instructions, refer to the SealClear Data Sheet, DSC426.

14. Maintenance and Repair

- 14.1. Refer to DryvitCARE™ EIFS Repair Procedures, DSC498.

DISCLAIMER

Information contained in this document conforms to standard detail and product recommendations for the installation of the Dryvit Outsulation MD System products as of the date of publication of this document and is presented in good faith. Dryvit Systems Canada assumes no liability, expressed or implied, as to the architecture, engineering or workmanship of any project. To insure that you are using the latest, most complete information, contact Dryvit Systems Canada.

** The Trained Contractor Certificate indicates certain employees of the company have been instructed in the proper application of Dryvit products and have received copies of Dryvit's Application Instructions and Specifications. The Trained Contractor Program is not an apprenticeship or endorsement. Each trained contractor is an independent company experienced in the trade and bears responsibility for its own workmanship. Dryvit Systems Canada assumes no liability for the workmanship of a trained contractor.