

Notes:

1. These details are meant to apply to both Outsulation Plus and Outsulation MD NC. Outsulation® MD NC requires the use of Primus® DM as the base coat/adhesive.
2. Dryvit recommends that ground floor applications and all facades exposed to abnormal stress, high traffic, or deliberate impact have the base coat reinforced with Panzer® 15 or 20 Mesh prior to Standard Plus Mesh. Location of high impact zones should be indicated in contract drawings.

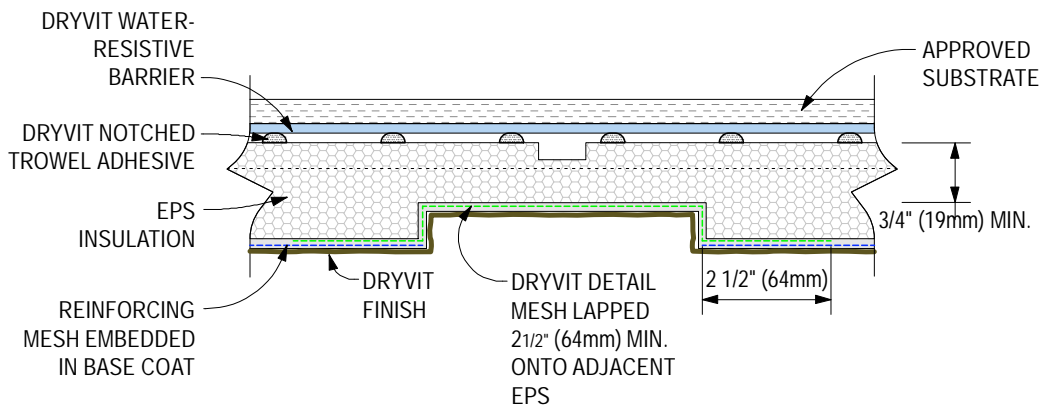
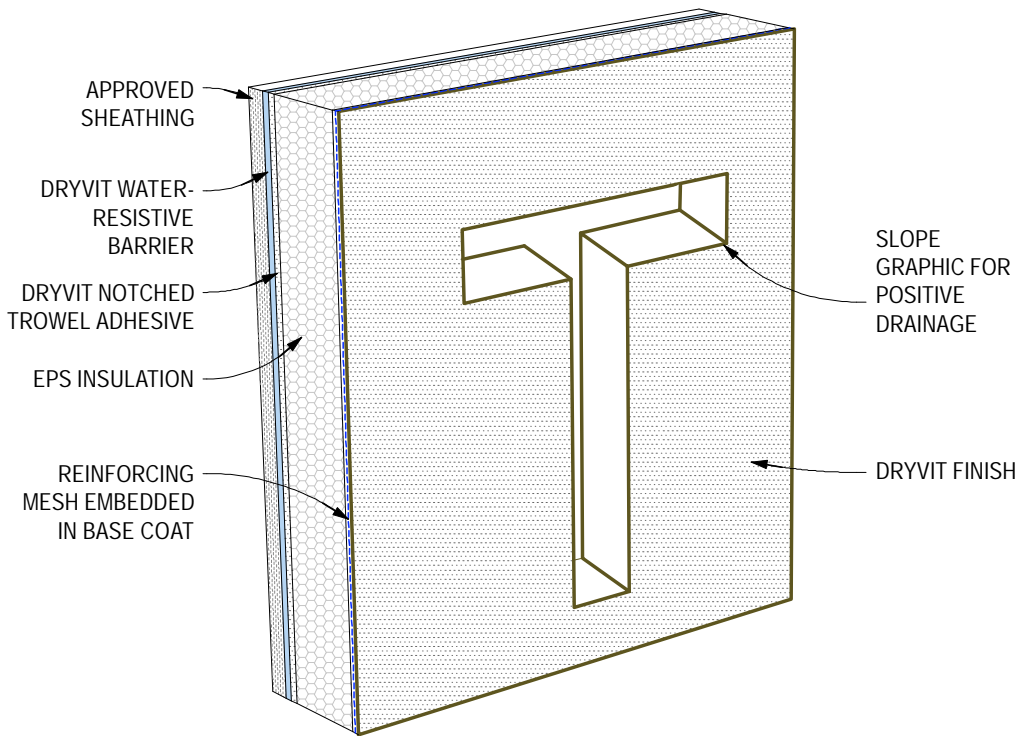

R-007-04-11

Recessed Graphics