

ULTRALATION[®] SYSTEM

A Mechanically Fastened,
Rugged, Exterior Wall
Insulation and Finish System



DS216

Ultralation System Application Instructions

INTRODUCTION

Dryvit Ultralation® is an Exterior Insulation and Finish System offering a tough, abuse-resistant, exterior finish, applied over Styrofoam™, a rigid insulation board manufactured by Dow Chemical USA which is mechanically fastened into the structural substrate.

Mechanical fastening into the structural substrate allows for flexibility of application with minimal wall preparation. Availability of a number of fastening systems makes the Ultralation System easily adaptable to a wide variety of wall systems. This includes various screw and washer combinations, as well as pneumatic driven fastening systems.

The Starter base coat is a polymer-modified cementitious mixture consisting of Starter acrylic mixture, Portland cement, Ultrafiber (fiberglass reinforcing fibers) and sand. The Starter mixture is applied at a thickness of ¼ inch to yield a durable, high-build exterior coating.

The Starter base coat can be finished smooth and coated with any of Dryvit Systems, Inc.'s wide variety of textured finishes, or it can be integrally textured and coated with Demandit®.

Note: The Starter mixture, a component of the Ultralation System is applied at a thickness of ¼ inch and leveled with a slicker, darby, rod or similar tool. Therefore, it must be applied by mechanics skilled in the use of these tools.

The finished aesthetics of a project are determined by workmanship which is the responsibility of the applicator/contractor.

I. Inspection of the Substrate

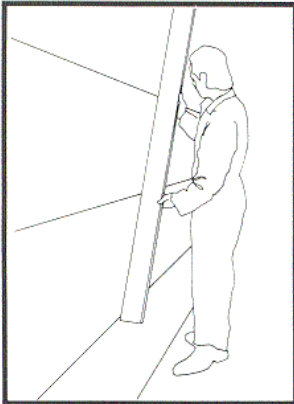

PRIOR TO INSTALLATION OF THE ULTRALATION SYSTEM CHECK THE SUBSTRATE TO INSURE THAT:

- A. It is structurally sound and free of crumbling or loose material, voids, projections etc.
- B. There are no planar irregularities greater than ¼ inch within any 4 foot radius.
- C. The substrate complies with all contract documents.
- D. The wall sheathing is securely attached to the wall framing as specified in the contract drawings.

Notify the General Contractor and/or Architect and/or Owner of all discrepancies. Do not proceed until all unsatisfactory conditions have been corrected.

II. Installation of Insulation Board, Ultramesh and Trim Accessories

A. MECHANICAL FASTENERS

1. The insulation board is attached to the substrate using fasteners consisting of a corrosion resistant screw or pneumatic driven pin in conjunction with a nominal 1 ½ inch diameter washer.
2. Use only approved fasteners as specified by Dryvit Systems, Inc.
3. Wood based substrates – the fastener must penetrate the structural base a minimum of ¾ inches.
4. Light gauge metal framing – the fastener must penetrate the studs a minimum of 3/8 inches.
5. Brick, masonry or concrete – the fastener must penetrate into the substrate a minimum of 1 inch.

Size the fastener lengths accordingly.

B. INSULATION BOARD INSTALLATION

1. Begin installation from a permanent or temporary support at the base of the wall. This provides a straight, level base for installing the insulation board.
2. From a full sheet of insulation, score and cut a 1 foot wide piece to use for the starter row. This will minimize the coinciding of insulation board joints and sheathing joints.
3. Install the insulation boards with the long dimension horizontally, beginning at the base of the wall and continuing up in a running bond pattern. Tightly butt all boards. Any gaps greater than 1/8 inch must be slivered or corrected by other Dryvit approved methods.

4. When installing insulation board over framed walls with non-structural sheathing, the insulation board ends must fall on a stud. This is not necessary when applied over minimum 1/2 inch exterior grade plywood.
5. Attach the insulation board to the structural substrate using two (2) fasteners for every 2' x 8' board. For larger boards, two (2) additional fasteners may be used. Install these fasteners within the field of the board – not along the perimeter. These fasteners must be installed so that the insulation board is snug to the wall and is slightly dimpled by the washer. The face of the washer should sit no more than 1/16 inch above the face of the insulation board. **DO NOT OVERDRIVE** the fasteners as this will damage the insulation board as well as the washer.
6. Stagger the edges of the insulation board at all outside and inside corners.
7. At penetrations where control joints will not be used, align the insulation boards so that the edges do not coincide with the corners of the opening. This will help to minimize cracking at these locations.
8. Measure and locate all control joints, and snap chalk lines on the face of the insulation board to designate locations. Generally control joints must be located as follows:
 - a) monolithic wall areas must not exceed 144 square feet
 - b) horizontal or vertical dimensions between control joints do not exceed 12 feet
 - c) length to width ratio of any wall area cannot exceed 2 1/2 to 1
 - d) at corners of all openings such as windows and doors.

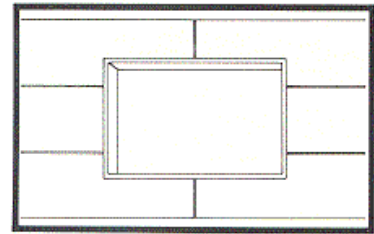
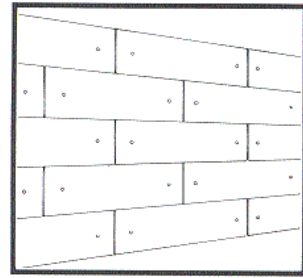

Refer to published Ultralation Details and Specifications for further guidelines.

9. Using a router or hot-knife, cut grooves along the chalk lines to receive the control joints. Size the groove to completely accommodate the control joint and allow for its free movement. Generally a 1/2 inch wide by 3/4 inch deep groove is adequate. Be careful not to cut through the entire thickness of the insulation board. Leave a minimum of 1/4 inch of insulation at the base of the groove.

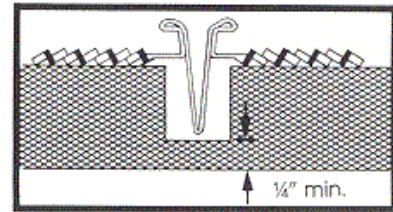

C. INSTALLATION OF TRIM ACCESSORIES

1. Refer to the Ultralation System Specification and published Ultralation Details for guidelines regarding location and installation of control joints, corner reinforcing beads and other trim accessories.
2. Install all control joints at this time. At all control joint intersections and abutments, apply a neutral cure (NOT ACID CURE) silicone or moisture cured urethane bedding sealant into the routed groove to prevent water entry at gaps between the control joint sections.

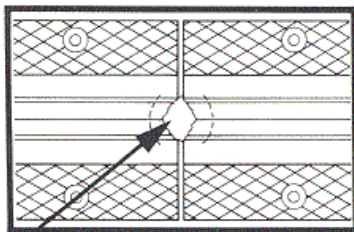

Provide neutral cure (not acid cure) silicone bedding sealant in area behind control joint intersection.

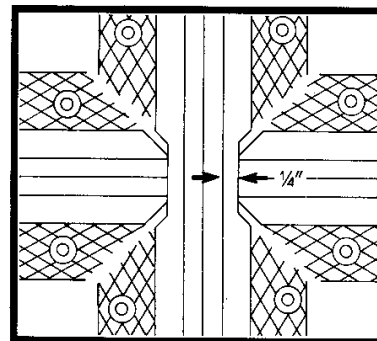

3. Where vertical and horizontal control joints intersect, run the vertical piece continuous and cut the horizontal pieces to connect to the vertical ones. Separate the control joints intersections with a 1/4 inch gap to allow for expansion/contraction. The control joint is then set into the bedding sealant such that this gap is completely filled.

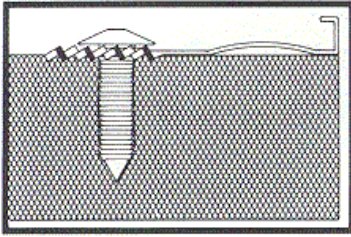

4. Install all other trim except metal corner accessories over the insulation board at this time. Use all-nylon fasteners to attach the trim to the insulation board. It is not necessary for the trim to be fastened to the substrate.

D. ULTRAMESH INSTALLATION

1. Inspect the insulation board installation to be sure that all boards are tightly butted and properly installed with no planar deviations greater than ¼ inch within a 4'-0" radius. Correct any irregularities at this time.
2. After all exposed trim accessories are installed, apply Ultramesh to the entire wall. Generally it is applied vertically, however, it can also be installed horizontally.
3. For all corners continue the Ultramesh past the corner and lap onto the Ultramesh from the other wall face.
4. Overlap the edges of the Ultramesh a minimum 2 ½ inches to a maximum of 4 inches.
5. Temporarily fasten the fabric to the insulation board using ¾ inch galvanized roofing nails, coated staples or all-nylon fasteners.
6. Stretch the mesh as flat as possible so that any waves or wrinkles are removed. . .DO NOT CUT ULTRAMESH TO REMOVE WRINKLES.
7. At outside corners, install welded wire corner reinforcement or expanded flange corner beads at this time. Use all-nylon fasteners to fasten them to the insulation board.
8. Install the remaining fasteners and washers to complete the installation of the insulation board and Ultramesh reinforcing fabric. Refer to Ultralation Details for complete fastening pattern. Contact Dryvit Systems, Inc. for recommendation on details and fastening patterns not specifically addressed.
9. Since Ultramesh has been installed continuously over the control joints and other trim, it is necessary to remove the excess. Using a sharp utility knife, cut the mesh along each exposed trim so that it lays flat and will not interfere with the Starter base coat application.

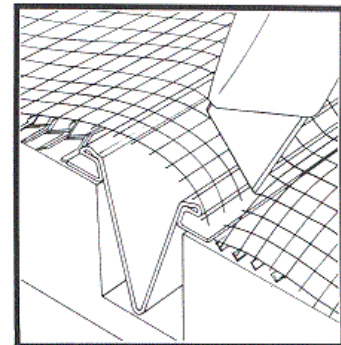
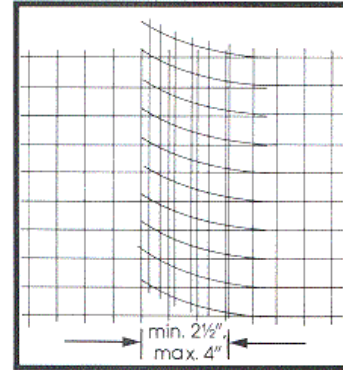

III. Starter Base Coat Application

A. STARTER BASE COAT MIXING

1. Materials
 - a. One pail (35 lbs.) Starter base liquid
 - b. One bag (94 lbs.) Type I or II gray or white Portland cement meeting the requirements of ASTM C-150
 - c. 200 lbs. #40 – 45 sieve, dry, bagged silica sand. Bulk sand may be used provided it meets the requirements of ASTM C-897
 - d. One bag Ultrafibers™
2. Directions
 - a. With mortar mixer engaged, add in this order:
 - 1) Starter base liquid
 - 2) Half the total amount of sand (100 lbs.)
 - 3) One bag (94 lbs.) Portland cement
 - 4) Remainder of sand (100 lbs.)
 - a) Mix for 3 – 5 minutes
 - b) After mixing is complete, disengage mixer and let the mix rest for 5 minutes

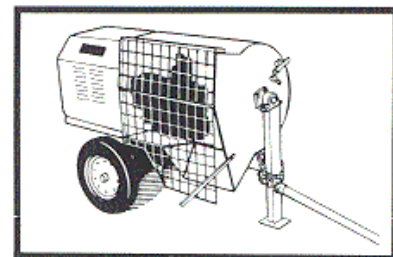

- c) Turn on mixer and add one bag of Ultrafibers and mix for 3 additional minutes. **DO NOT OVERMIX!**
- d) Add clean potable water as needed to adjust workability. **DO NOT OVERWATER!**

CAUTION:

- Do not use wet sand.
- For hot weather, mix half batches and use cool water.
- Clean mortar mixer regularly. Running continuous batches without cleaning may cause the set of subsequent batches to be accelerated.

B. STARTER BASE COAT APPLICATION FOR DRYVIT FINISHES

1. Inspect the wall to ensure the surface temperature is above 40°F. Starter is to be applied only when the surface and ambient temperature is 40°F and above and must remain so for a minimum of 24 hours. If this is not the case, supplemental heat must be provided.
2. Check the wall to be certain the insulation board, Ultramesh and trim accessories have been properly installed. Specifically check that:
 - a. fasteners are installed correctly and properly spaced
 - b. all insulation boards are tightly butted
 - c. control joints and other accessories are properly located and installed
 - d. there are no wrinkles, tears, cuts or waves in the Ultramesh
 Small breaks in the Ultramesh may be repaired by applying a piece of Ultramesh over the damaged area and embedding it in the first tight coat of the Starter mixture.

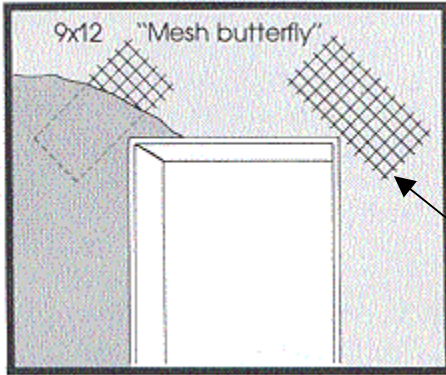

3. Trowel on the first coat of Starter mixture.

At this time where diagonal reinforcing fabric is required to reinforce corners at penetrations, embed a 9 inch by 12 inch piece of Ultramesh in the Starter base coat, between the first and final coat.

To minimize cracking at all doors & windows that do not utilize control joints at corners.



Immediately double back adding additional material to achieve a smooth surface ¼ inch thick. Strike to a smooth, level plane using a rod, darby, slicker or other similar tool.

Apply the Starter base coat to an entire panel without interruption to avoid cold joints. Wet Starter base coat shall abut set base coat at naturally occurring interruptions such as casing beads or control joints.

4. After initial set, remove any trowel marks or other irregularities from the base coat which may interfere with the finish coat application.
5. For finer finishes like Sandblast®, care must be taken that the base coat is flat and smooth. Skim coating may be required prior to applying these finishes. Starter, Primus® or Genesis® mixture may be used to bring the surface flat.

C. APPLYING A TEXTURED STARTER BASE COAT FOR FINISHING WITH DEMANDIT®

1. Inspect the wall to ensure the surface temperature is above 40°F. Starter is to be applied only when the ambient and surface temperature is 40°F and above and must remain so for a minimum of 24 hours. If this is not the case, supplemental heat must be provided.
2. Check the wall to be certain the insulation board, Ultramesh and trim accessories have been properly installed. Specifically check that:
 - a. fasteners are installed correctly and properly spaced
 - b. all insulation boards are tightly butted
 - c. control joints and other accessories are properly located and installed
 - d. there are no wrinkles, tears, cuts or waves in the Ultramesh

Small breaks in the Ultramesh may be repaired by applying a piece of Ultramesh over the damaged area and embedding it in the first tight coat of the Starter mixture.

3. Trowel on the first coat of Starter mixture.

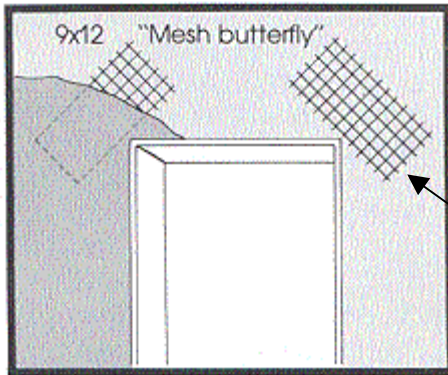

At this time where diagonal reinforcing fabric is required to reinforce corners at penetrations, embed a 9 inch by 12 inch piece of Ultramesh in the Starter base coat, between the first and final coat.

To minimize cracking at all doors & windows that do not utilize control joints at corners.

Immediately double back adding additional material to achieve a smooth surface ¼ inch thick. Strike to a smooth, level plane using a rod, darby, slicker or other similar tool.

Apply the Starter base coat to an entire panel without interruption to avoid cold joints. Wet Starter base coat shall abut set base coat at naturally occurring interruptions such as casing beads or control joints.

4. After initial set, remove any trowel marks or other irregularities from the base coat which may interfere with the Starter texture coat application.
5. Trowel apply the desired texture to the set base coat using the Starter mixture. For best results apply the texture after the base coat has set but before it has fully dried. Depending on the desired aesthetics, Ultrafibers may be left out of the Starter texture mixture.

NOTE: ULTRAFIBERS MUST BE USED IN THE BASE COAT MIXTURE.



IV. Special Insulation Board Shapes

A. SPECIAL SHAPES ARE EASILY INCORPORATED AS PART OF THE ULTRALATION SYSTEM AND REQUIRE THE USE OF EXPANDED POLYSTYRENE (EPS) INSULATION BOARD. DRYVIT PRIMUS AND DETAIL® REINFORCING MESH AND ARE INSTALLED OVER THE CURED STARTER BASE COAT.

1. Due to shipping, there may be some setting of the Primus. Remix the material using a mixer such as a Goldblatt Jiffler No. 15311H7 powered by a ½ inch drill, 400 – 500 RPM only.

CAUTION: Do not overmix as air entrapment and product damage may occur and result in workability and performance problems.

2. Use a clean plastic container. Pour ½ of the freshly mixed Primus (approximately 30 lbs.) into the container.

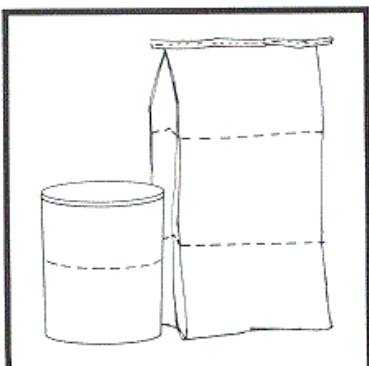

3. While mixing, add 30 lbs. (approximately 1/3 of a bag) of Type I or Type II Portland cement to the Primus in small increments and mix thoroughly each time.
4. Clean potable water may be added to the Primus to adjust workability. Add as little water as possible, in small increments and ONLY after the Portland cement is thoroughly mixed. The Primus should be sticky and have enough body to hold the insulation board in place without slipping.

CAUTION: Do not overwater as this will degrade the performance of the product.

5. It is advisable to mix the Primus with Portland cement thoroughly then “wait 5 minutes” and mix again to break the initial set. Retempering with a small amount of water is permissible as long as the Primus mixture has not set.
6. Smaller quantities may be mixed provided the correct proportions are maintained (1 lb. Primus to 1 lb. Portland cement).
7. Using a stainless steel trowel, install a ribbon of Primus mixture 2 inches wide by 3/8 inch thick around the entire perimeter of the shape. Place dabs of Primus approximately 12 inches apart on the remaining area. A 3/8 inch notched trowel may also be used.
8. Immediately position the foam shape on the wall adhering to the set Starter base coat.
9. Allow to set for 24 hours.
10. Mix additional Primus as described above and trowel over the entire surface of the shape in a uniform thickness of approximately 3/32 inch. Immediately place the Detail Reinforcing Mesh against the wet Primus mixture and fully embed.
11. Lap the Primus and reinforcing mesh over the Starter base coat for a minimum of 2 ½ inches.
12. After the Primus base coat has been allowed to dry for 24 hours, it is ready for application of the Dryvit finish or Starter texture with Demandit.
13. Let the finish dry for 24 hours.
14. Apply a fillet caulk with bond breaker tape along the intersection of the top surface of the shape and the wall.

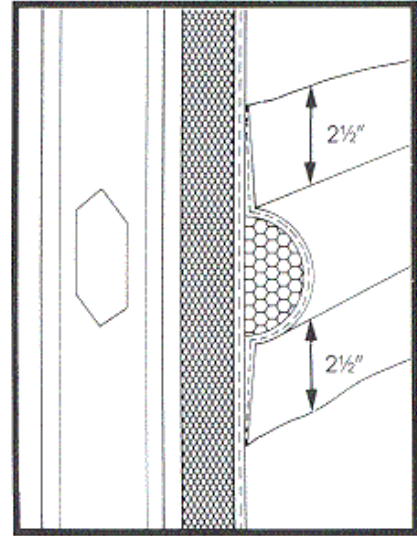

V. Application of Dryvit Finish

A. THE FOLLOWING DRYVIT FINISHES ARE ACCEPTABLE FOR EXTERIOR USE AS PART OF THE ULTRALATION SYSTEM.

1. Standard DPR (Dirt Pick-up Resistant) Finishes
 - a. Quarzputz, Sandblast, Sandpebble, Sandpebble Fine, and Freestyle.

2. Elastomeric DPR (Dirt Pick-up Resistant) Finishes
 - a. Weatherlastic Quarzputz, Weatherlastic Sandpebble, Weatherlastic Sandpebble Fine, Weatherlastic Adobe™, and Weatherlastic Smooth.

3. Medallion Series PMR™ (Proven Mildew Resistance)
 - a. Quarzputz, Sandblast, Sandpebble, Sandpebble Fine, Demandit and Freestyle.

4. Specialty Finishes
 - a. Ameristone, Stone Mist, and Custom Brick

B. PRIOR TO APPLYING THE DRYVIT FINISH, THE STARTER BASE COAT SHALL HAVE CURED A MINIMUM OF 24 HOURS AND SHALL BE DRY AND HARD. CURE TIME MAY BE LONGER DEPENDING ON ENVIRONMENTAL CONDITIONS.

C. INSPECT THE STARTER BASE COAT FOR ANY IRREGULARITIES SUCH AS TROWEL MARKS, BOARD LINES, ROUGH CORNERS AND EDGES, PROPER REINFORCING MESH EMBEDMENT AS WELL AS EFFLORESCENCE. NOTE: Correct all irregularities and remove all efflorescence prior to applying the Dryvit Finish.

IMPORTANT: The Starter base coat surface must be flat, smooth and free of any irregularities. Skim coating may be necessary.

D. MIXING THE DRYVIT FINISH

1. Quarzputz®, Sandblast®, Freestyle®, Sandpebble®, Sandpebble Fine™ and Weatherlastic® Finishes. Thoroughly mix the factory-prepared Dryvit finish with a Wind-lock B-M1 or B-MB mixing blade (or equivalent) until a uniform homogeneous consistency is attained. A small amount of clean potable water may be added to adjust workability. **Always add the same amount of water to each pail within a given lot to avoid color variation.**

2. Specialty Finishes
 - a. Ameristone™ and Stone Mist®.

- 1) Mix the factory-prepared finish for a maximum of 1 to 1-1/2 minutes with a Wind-lock B-M1 or B-M8 mixing blade (or equivalent) powered by a 13 mm (1/2 in.) drill, 400-500 RPM, just prior to

application. **Do not overmix. Over mixing can result in air entrapment that will affect application and color. Tip: Mix each bucket of material for the same length of time.**

b. Custom Brick

- 1) Refer to Dryvit Custom Brick Application Instructions DS154 and DS214 for complete mixing and usage instructions.

E. APPLICATION

1. General

Important: All Dryvit finishes must be installed continuously to a natural break such as corners, expansion joints, or tape line. Mechanics must maintain a wet edge. Whenever possible, order enough material in a single batch to complete the project to avoid potential color variations from batch to batch. Sufficient personnel and scaffolding must be provided to continuously finish a distinct wall area or otherwise cold joints will result. Scaffolding must be spaced a minimum of 460 mm (18 in) from the wall to prevent staging lines. On hot windy days, the wall may be fogged with clean potable water to cool the wall and facilitate finish installation. As with other plaster materials, installation work should precede the sun. For example, work the shady or cool side of the building. If this is not possible, scaffold should be shaded with a tarp or nursery shade cloth. Do not introduce water to the finish material once it is installed on the wall. This will cause color variations. Each mechanic must use the same tool and hand motion and match the texture of the mechanics above, below and on each side. Use finish from a single batch number whenever possible. **IMPORTANT: Remember – Color is Texture, Texture is Color.**

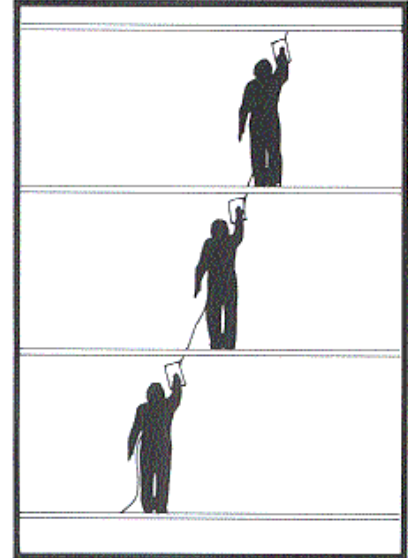

CAUTION: DO NOT APPLY FINISH IN SEALANT JOINTS. Refer to Section VII for proper preparation of sealant joints

2. Quarzputz, Sandblast, and Weatherlastic Quarzputz

- a. Mix the Dryvit finish as described in Section V.D.1 **Warning: Do not apply the Dryvit materials in the rain. The base coat surface must be dry prior to applying the Dryvit Finish material.**
- b. Using a clean stainless steel trowel, apply a coat of the Dryvit finish in a uniform thickness on the dry base coat. **Note: The Dryvit Quarzputz finish shall be applied and leveled to a uniform thickness no greater than the largest aggregate. The Sandblast finish is applied and leveled to a thickness of approximately 1 1/2 times the largest aggregate.**
- c. The texture is achieved by uniform hand motion and/or tool that produces the texture to match the approved sample. Each mechanic must use the same tool and hand motion to ensure that the texture achieved is uniform over the entire wall area.

3. Sandpebble, Sandpebble Fine, Weatherlastic Sandpebble, and Weatherlastic Sandpebble Fine

- a. Mix the Dryvit finish as described in Section V. D. 1. **Warning: Do not apply the Dryvit materials in the rain. The base coat surface must be dry prior to applying the Dryvit Finish material.**
- b. Using a clean, stainless steel trowel, apply an even coat of the finish to a thickness slightly thicker than the largest aggregate size.
- c. Pull across using a horizontal trowel motion to develop a uniform thickness no greater than the largest aggregate of the material.
- d. The texture is achieved by a uniform hand floating motion with a clean stainless steel trowel; wipe the trowel and wet it lightly. Apply light pressure in a circular motion.

4. Freestyle

- a. Mix the Dryvit finish as described in Section V. D. 1. **Warning: Do not apply the Dryvit materials in the rain. The base coat surface must be dry prior to applying the Dryvit Finish material.**
- b. Using a clean, stainless steel trowel, apply the Freestyle finish on the base coat in a thickness not greater than 1.6 mm (1/16 in). The texture is either pulled out of this base to a thickness of no greater

than 6.3 mm (1/4 in), or the texture may be achieved by adding more Freestyle finish to the base coat using the same texturing motions that are used with other plaster materials - such as a skip trowel finish. Numerous other aesthetically pleasing textures can be created to match approved samples.

NOTE: The maximum thickness of any Freestyle finish texture shall not exceed 6.3 mm (1/4 in.)

5. Application of Demandit®
 - a. Inspect the base coat.
 - 1) Allow the textured Starter base coat to cure a minimum of 24 hours. It must be dry and hard before proceeding with the finish coat application. Cool, humid conditions may require longer curing time.
 - 2) Inspect the textured base coat for any irregularities which will interfere with the application of the finish coat. Correct prior to applying the Demandit finish coat.
 - 3) Check to ensure that the surface and ambient temperature is above 45°F. Demandit is to be applied only when the temperatures are 45°F or above and must remain so for a minimum of 24 hours. Otherwise, supplemental heat must be provided.
 - b. Mixing the Demandit
 - 1) Stir Demandit to a smooth, homogeneous consistency. Avoid introducing air into the coating.
 - c. Applying Demandit
 - 1) Apply with a brush, roller, or airless spray equipment.
 - 2) When applying with a roller, a maximum 19 mm (3/4 in) nap, polyester or polyester blend with nylon or lambswool, with beveled ends and a phenolic core is recommended. A 460 mm (18 in) wide roller frame with a 57 mm (2 ¼ in) inside diameter is also recommended.
 - 3) When applying Demandit do so in one continuous coat, maintaining a wet edge as the application proceeds to a natural break. The roller cover must be kept fully loaded as the application proceeds.
CAUTION: Do not stretch out the application by rolling with a dry roller. The last leveling roller strokes should always be in the same direction. Do not cut in around openings prior to overall application, but rather, do the cut-in work as the application proceeds. Tips: Application of Demandit should always be done by an experienced, industrial or commercial painting contractor. Porous surfaces may require two coats to obtain a uniform appearance. Changing color requires the application of two coats. Do not allow the Demandit to dry on roller covers. Roller covers with dried coating do not apply the coating evenly.
6. Weatherlastic Adobe
 - a. Using a brush, roller or airless spray equipment, apply a coat of color coordinated Color Prime at the recommended coverage to the cured base coat and allow to dry.
 - b. Mix the Adobe finish material as described in Section V.D.1. **Warning: Do not apply the Dryvit materials in the rain. The base coat surface must be dry prior to applying the Dryvit Finish material.**
 - c. Using a stainless steel trowel, apply a coat of Adobe approximately 1.6 mm (1/16 in) to the wall surface. Allow the Adobe finish to take-up.
 - d. Using a stainless steel trowel, apply a second coat of Adobe to obtain the desired texture. **Tip: An atomizing spray bottle may be used to apply a mist of water to the surface in the finishing step.**
7. Ameristone
 - a. Mix the Ameristone Finish as described in Section V.D.2.
 - b. Apply Ameristone finish in accordance with Ameristone Application Instructions, DS142. **CAUTION: Do not apply Ameristone in sealant joints. . Warning: Do not apply Dryvit materials in the rain. The base coat surface must be dry prior to applying the Dryvit Ameristone finish material.**
8. Stone Mist
 - a. Mix the Stone Mist Finish as described in Section V.D.2.
 - b. Apply Stone Mist finish in accordance with Stone Mist Application Instructions, DS420.
Warning: Do not apply the Dryvit materials in the rain. The base coat surface must be dry prior to applying the Dryvit Stone Mist finish material.
9. Custom Brick
 - a. Refer to Dryvit Custom Brick Application Instructions, DS154 and DS214, for complete usage instructions. **Warning: Do not apply the Dryvit materials in the rain. The base coat surface must be dry prior to applying the Dryvit Custom Brick finish material.**

VII. Sealant Joint Preparation

- A. ALL SEALANT JOINTS SHALL BE PREPARED WITH EITHER DRYVIT DEMANDIT OR COLOR PRIME.
1. Stir Demandit or Color Prime to a smooth, homogeneous consistency.
 2. Apply Demandit or Color Prime with a brush on each side of the joint.
 3. Allow the Demandit or Color Prime to dry a minimum of 24 hours prior to sealing with recommended sealant as listed in DS153.

VIII. Repair Procedure

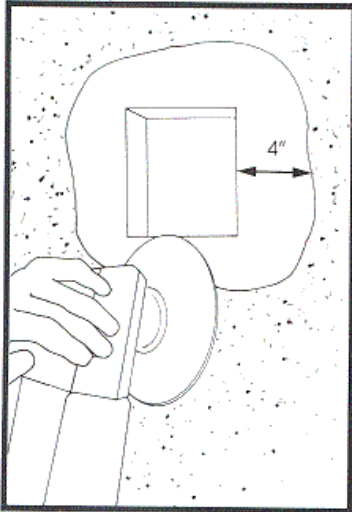

1. Cut out and remove affected area using a power saw with a masonry cutting blade.
2. Using a disk grinder, remove finish and 1/8 inch of the Starter base coat for 4 inches around the damaged area. Be careful not to damage the Ultramesh within this area.
3. Cut a piece of insulation board to fit tightly into the damaged area and install in place.
4. Apply Starter mixture over the insulation board and onto the overlap area at approximately 1/8 inch thickness, and immediately install a layer of Ultramesh in the Starter mixture such that it is fully embedded.
5. Apply Starter as needed to bring level with undamaged base coat.
6. Allow Starter to set for 24 hours prior to applying finish coat.

CAUTION:

- For steps 4, 5, and 6, it will be necessary to mask out the repair area to avoid splatter onto undamaged area.
- Where damaged area spans over studs, use fasteners to attach Ultramesh and insulation board to studs.

DISCLAIMER

Information contained in this document conforms to standard detail and product recommendations for the installation of the Dryvit Ultralation System products as of the date of publication of this document and is presented in good faith. Dryvit Systems, Inc. assumes no liability, expressed or implied, as to the architecture, engineering or workmanship of any project. To insure that you are using the latest, most complete information, contact:

Dryvit Systems, Inc.,
 One Energy Way
 P.O. Box 1014
 West Warwick, RI 02893
 (401) 822-4100

** The Trained Contractor Certificate indicates certain employees of the company have been instructed in the proper application of Dryvit products and have received copies of Dryvit's Application Instructions and Specifications. The Trained Contractor Program is not an apprenticeship or endorsement. Each trained contractor is an independent company experienced in the trade and bears responsibility for its own workmanship. Dryvit System's, Inc. assumes no liability for the workmanship of a trained contractor.

Dryvit Systems, Inc.
 P.O. Box 1014
 One Energy Way
 West Warwick, RI 02893
 800-556-7752
 www.dryvit.com

