

# OUTSULATION<sup>®</sup> PLUS MD SYSTEM<sup>®</sup>



DS218

An Exterior Wall Insulation and Finish System with a Water-Resistive Barrier

## Outsulation Plus MD System Application Instructions

<b>Table of Contents</b>	
Section I	General Installation Requirements
Section II	Materials Required for Completing Installation of the Outsulation Plus MD System
Section III	Mixing Instructions
Section IV	Rough Opening Preparation Options
Section V	Substrate Expansion Joint Bridging Options
Section VI	Air/Water-Resistive Barrier Application
Section VII	Accessories
Section VIII	Insulation Board Installation
Section IX	Installation of Reinforcing Mesh and Base Coat
Section X	Sealant Joint Preparation
Section XI	Dryvit Primers
Section XII	Dryvit Finish
Section XIII	Coatings and Sealers
Section XIV	Maintenance and Repair

**I. General Installation Requirements**

**A. Project Conditions**

1. Storage

a. Maximum storage temperature shall not exceed 38 °C (100 °F). Minimum storage temperature shall not be less than 4 °C (40 °F) with the exception of the following products:

- 1) Demandit® and Revyvite®: 7 °C (45 °F).
- 2) Ameristone™, TerraNeo®, Limestone™, and Reflectit™: 10 °C (50 °F).
- 3) Custom Brick™ Finish: refer to Custom Brick Polymer Specification, DS151.
- 4) For other products, refer to specific product data sheets.

2. Application

a. Application of wet materials shall not take place during inclement weather unless appropriate protection is provided.

b. Protect materials from inclement weather until they are completely dry.

c. Air and surface temperatures must be 4 °C (40 °F) or above and must remain so for a minimum of 24 hours or until dry at the time of Dryvit product application with the exception of the following products:

- 1) Demandit® and Revyvite®: 7 °C (45 °F).
- 2) Ameristone™, TerraNeo®, Limestone™, and Reflectit™: 10 °C (50 °F).
- 3) Custom Brick Finish: refer to Custom Brick Polymer Specification, DS151.
- 4) For other products, refer to specific product data sheets.

5) These temperatures shall be maintained with adequate air ventilation and circulation for a minimum of 24 hours (48 hours for Ameristone, TerraNeo and Limestone) thereafter, or until the products are completely dry. Cool, humid conditions may require longer drying times.

**B. Inspection of Substrate**

1. Acceptable substrates for application of the Dryvit Outsulation Plus MD System are listed in the Dryvit Outsulation Plus MD System Specification, DS137.

2. The substrate must be securely fastened per contract documents.

3. The substrate attachment method must comply with all contract documents.

4. The substrate must be clean, dry, structurally sound, free of loose material, voids, projections, hot spots, release agents, coatings, or other materials that may affect adhesion.

5. There shall be no planar irregularities greater than 6.4 mm (1/4 in) within any 1.2 m (4 ft) radius.

6. Wood based sheathings require a 3.2 mm (1/8 in) gap between adjacent sheets per the guidelines published by the APA.

**C. Flashing at System Terminations**

1. General

a. Ensure that flashing is installed in accordance with applicable code requirements and the contract documents. As a minimum, opening preparation is required as shown in the Outsulation Plus MD System Installation Details, DS110.

2. Transition at Roof Lines

a. Ensure the roof has positive drainage, i.e. all runoff shall be directed to the exterior and away from the structure.

b. Roof flashing (by others) shall be installed in accordance with industry guidelines, manufacturer's instructions and contract documents.

c. Runoff diverters (i.e. kickouts, crickets and saddles) (by others) shall be installed in accordance with industry guidelines, manufacturer's instructions and contract documents. Particular attention must be paid to the eaves/chimney intersections and sloped roof/wall intersections. Refer to the Dryvit Outsulation Plus MD System Installation Details, DS110.

d. Hold system a minimum of 203 mm (8 in) above flat roofs; 51 mm (2 in) above sloped roofs.

3. Openings

a. Heads, jambs and sills of all openings shall be prepared with Dryvit Backstop® NT, AquaFlash®, Flashing Tape™ or other approved flashing material selected by the design professional prior to window/door, mechanical equipment, or other component installation. For proper application, refer to the Dryvit Outsulation Plus MD System Installation Details, DS110.

**NOTE: Sill piece shall extend to the inside face of wall and continue a minimum of 102 mm (4 in) up at the jambs.**

b. Continuous flashing at heads of openings as indicated in contract documents. **NOTE: For windows or doors that do not have integral flashing, a field-applied flashing shall be installed (by others) in accordance with industry guidelines, manufacturer's instructions and contract documents. Refer to the Dryvit Outsulation Plus MD System Installation Details, DS110.**

c. Individual windows that are ganged to make multiple units require the heads to be continuously flashed and the joints between the units to be fully sealed.

- 4. Decks and Patios
  - a. Wood decks shall be properly flashed prior to system application. See the Dryvit Outsulation Plus MD System Installation Details, DS110
  - b. Verify that the system terminates above poured decks, patios, landings, etc. and that they are properly sloped and waterproofed to direct water away from the walls.
- 5. Utilities
  - a. Provisions must be made to ensure that the system terminates properly at lighting fixtures, electrical outlets, hose bibs, dryer vents, etc. Refer to the Dryvit Outsulation Plus MD System Installation Details, DS110 for general information and guidance.
- 6. Grade Level Terminations
  - a. Hold system a minimum of 203 mm (8 in) above finished grade.
- D. Sealants
  - 1. Dryvit materials shall be completely dry prior to installation of sealant materials (typically 48 - 72 hours). Humid or cool conditions may require longer drying times.

**Notify the general contractor and/or architect and/or owner of all discrepancies. Do not proceed until all unsatisfactory conditions have been corrected.**

**II. Materials Required for Completing Installation of the Outsulation Plus MD System**

**A. Materials Supplied by Dryvit Systems, Inc.**

- 1. AquaFlash and AquaFlash Mesh
- 2. Backstop NT – Texture and/or Backstop NT – Smooth, or Backstop DMS
- 3. Grid Tape™
- 4. Dryvit Flashing Tape and Flashing Tape Surface Conditioner™
- 5. AP Adhesive™
- 6. Drainage Track
- 7. Drainage Strip™
- 8. Starter Strip™- optional
- 9. Track - optional
- 10. Genesis®, Genesis® DM, Genesis® DMS, Primus®, Primus® DM, Dryflex®
- 11. NCB™
- 12. Genesis® FM
- 13. Rapidry™ DM 35-50, Rapidry™ DM 50-75, RapidPatch™
- 14. Standard Mesh, Standard Plus Mesh, Intermediate Mesh, Panzer® 15, Panzer 20, Corner Mesh, and Detail Mesh®
  - a. It shall be colored blue for product identification bearing the Dryvit logo.
- 15. Dryvit Finishes
- 16. Dryvit Coatings and Primers

**NOTE: Materials listed above are those contained or referenced in the Outsulation Plus MD Specification, DS137. Typically the project specification will identify the specific materials necessary to complete application.**

**B. Materials Supplied by Others**

- 1. Portland Cement: Type I or II
- 2. Clean Potable Water
- 3. Expanded Polystyrene Insulation Board meeting DS 131

**III. Mixing Instructions**

**A. General**

- 1. No additives such as sand, aggregates, rapid binders, anti-freeze, accelerators, etc. shall be added to any Dryvit materials under any circumstances. **Such additives will adversely affect the performance of the material and void all warranties.**

**B. Water-Resistive Barrier/Air Barrier Materials**

- 1. AquaFlash
  - a. Open the bucket with a utility knife or lid-off.
  - b. AquaFlash is ready to use after an initial spin-up using a “Twister” paddle or equivalent mixing blade, powered by a 12.7 mm (1/2 in) drill, at 450 - 500 rpm. Do not add cement or any other additives.
- 2. Backstop NT
  - a. Open the bucket with a utility knife or lid-off.
  - b. Backstop NT is ready to use after an initial spin-up using a “Twister” paddle or equivalent mixing blade, powered by a 12.7 mm (1/2 in) drill, at 450 - 500 rpm. Do not add cement or any other additives.
- 3. Backstop DMS (can also be used as adhesive)
  - a. See DS704 for mixing instructions

**C. Adhesive and Base Coat**

- 1. Primus, Genesis, or Genesis FM
  - a. Open the bucket with a utility knife or lid-off.

- b. Due to shipping and storage, there may be some separation of materials. Prior to splitting the material and adding Portland cement, mix the material thoroughly. Use a “Twister” paddle or equivalent mixing blade powered by a 12.7 mm (1/2 in) drill, at 500 - 1200 rpm only. **NOTE: A minimum 7 amp drill works best for Portland cement based materials. CAUTION: Do not over-mix or use other types of mixing blades as air entrapment and product damage may occur and result in workability and performance problems.**
  - c. Pour 1/2 of the freshly mixed material [approximately 13.5 kg (30 lbs)] into a clean plastic container.
  - d. Add 1/3 of a bag [approximately 13.5 kg (30 lbs)] of fresh, lump free Type I or II Portland cement. Either gray or white cement is acceptable. Add cement slowly and mix thoroughly. **Do not add large quantities of cement at one time.**
  - e. Clean potable water may be added to the mixture to adjust the workability.
    - 1) Primus
      - a) Add as little water as possible, in small increments, and only after the Portland cement is thoroughly mixed. **Do not over water as this will degrade the performance and promote efflorescence.**
      - b) Mix the Primus material with Portland cement thoroughly; then wait five (5) minutes and mix again to break the initial set. Retempering with a small amount of water is permissible provided the mixture has not set. The mixture has a pot life similar to other Portland cement plaster material. Mix only as much material as can be conveniently used during a work period.
    - 2) Genesis and Genesis FM
      - a) Add 950 ml (1 qt) of water prior to adding Portland cement. Additional water may be added to adjust workability.
      - b) Mix the Genesis material with Portland cement thoroughly; then wait ten to fifteen (10-15) minutes and mix again to break the initial set. Retempering with a small amount of water is permissible provided the mixture has not set. The mixture has a pot life similar to other Portland cement plaster material. Mix only as much material as can be conveniently used during a work period.
2. Primus DM
- a. Pail Mixing
    - 1) One 22.7 kg (50 lb) bag of material will produce approximately 19 L (5 gal) of Primus DM mixture. Add 5.7 L (1.5 gal) of clean potable water into a clean plastic container.
    - 2) Add Primus DM slowly while mixing using a “Twister” paddle or equivalent mixing blade, powered by a 12.7 mm (1/2 in) drill, at 500 - 1200 rpm. **NOTE: A minimum 7 amp drill works best for Portland cement based materials.**
    - 3) Thoroughly mix until uniformly wetted, adjusting consistency with a small amount of water or Primus DM material.
    - 4) Allow the mixture to set a minimum of five (5) minutes then retemper, adding a small amount of water if necessary. Material must be free of lumps before using.
  - b. Mortar Mixer
    - 1) Add 5.7 L (1.5 gal) of clean potable water for each 22.7 kg (50 lb) bag of Primus DM into a clean mortar mixer.
    - 2) Add the Primus DM while the mixer is running. Let mix three to five (3 – 5) minutes, shut mixer off for five (5) minutes, then run mixer for another two to three (2 – 3) minutes to break the set and add a small amount of water if necessary to adjust the workability. The pot life is one to three (1 - 3) hours depending on weather.
3. Genesis DM
- a. Pail Mixing
    - 1) One bag of Genesis DM will produce approximately 19 L (5 gal) of Genesis DM mixture. To a clean 19 L (5 gal) pail, add 5.7 - 6.6 L (6 - 7 qt) of clean potable water.
    - 2) Add the Genesis DM slowly while constantly mixing with a “Twister” paddle or equivalent mixing blade, powered by a 12.7 mm (1/2 in) drill, at 500 - 1200 rpm. **NOTE: A minimum 7 amp drill works best for Portland cement based materials.**
    - 3) Thoroughly mix until uniformly wetted, adjusting consistency with a small amount of water or Genesis DM.
    - 4) Let set for ten (10) minutes. Retemper, adding a small amount of water if necessary. Material must be free of lumps before using.
  - b. Mortar Mixer
    - 1) Add 5.7 - 6.6 L (6 - 7 qt) of clean potable water for each 22.7 kg (50 lb) bag of Genesis DM into a clean mortar mixer.
    - 2) Add the Genesis DM while the mixer is running. Let mix three to five (3 – 5) minutes, shut the mixer off for ten (10) minutes, then run mixer for another two to three (2 – 3) minutes to break the set adding a small amount of water if necessary to adjust workability. The pot life is one to one and one half (1 – 1 ½) hours depending on weather.
4. Genesis DMS
- a. Sprayer
    - 1) Connect a source of clean, cool potable water to a spray machine suitable for EIFS applications.

- 2) Regulate the water flow rate to provide the desirable mixing consistency of material. Material may thicken up upon leaving the mixing cylinder at a given water flow and loosen up after pumping. **NOTE: The consistency for application must be determined after pumping.**

b. Pail Mixing

- 1) One bag of Genesis DMS will produce approximately 19 L (5 gal) of Genesis DMS mixture. To a clean 19 L (5 gal) pail, add 6.6 - 8.5 L (7 - 9 qt) of clean, cool potable water.
- 2) Add the Genesis DMS slowly while continuously mixing with a "Twister" paddle or equivalent mixing blade, powered by a 12.7 mm (1/2 in) drill, at 500 - 1200 rpm. **NOTE: A minimum 7 amp drill works best for Portland cement based materials.**
- 3) Thoroughly mix until uniformly wetted, adjusting consistency with a small amount of water or Genesis DMS.
- 4) Let set for five (5) minutes. Retemper, adding a small amount of water if necessary. Material must be free of lumps before using.

c. Mortar Mixer

- 1) Add 6.6 - 8.5 L (7 - 9 qt) of clean, cool potable water for each 22.7 kg (50 lb) bag of Genesis DMS into a clean mortar mixer.
- 2) Add the Genesis DMS while the mixer is running. Let mix three to five (3 – 5) minutes, shut the mixer off for five (5) minutes, then run mixer for another two to three (2 – 3) minutes. Retemper, adding a small amount of water if necessary. Material must be free of lumps before using. The pot life is one to three (1 - 3) hours depending on weather.

5. Rapidry DM 35-50

a. Pail Mixing

- 1) One 22.7 kg (50 lb) bag of Rapidry DM 35-50 will produce approximately 19 L (5 gal) of Rapidry DM 35-50 mixture. To a clean Dryvit 19 L (5 gal) pail, add 6.1 L (6.5 qt) of clean potable water. As an alternative, on the inside of the Dryvit 19 L (5 gal) pail, draw a horizontal line which measures 113 mm (4 7/16 in) from the base of the pail and fill with water.
- 2) Add the Rapidry DM 35-50 slowly while mixing with a "Twister" paddle or equivalent mixing blade, powered by a 12.7 mm (1/2 in) drill, at 500 - 1200 rpm. **NOTE: A minimum 7 amp drill works best for Portland cement based materials.**
- 3) Thoroughly mix until uniformly wetted, adjusting consistency with a small amount of water or Rapidry DM 35-50 material. Material must be free of lumps before using.

b. Mortar Mixer

- 1) Add 6.1 L (6.5 qt) of clean potable water for each 22.7 kg (50 lb) bag of Rapidry DM 35-50 into a clean mortar mixer.
- 2) Add the Rapidry DM 35-50 while the mixer is running. Mix for three to five (3 - 5) minutes adjusting consistency with a small amount of water or Rapidry DM 35-50. Material must be free of lumps before using. The pot life is approximately 30 minutes depending on temperature.

6. Rapidry DM 50-75

a. Pail Mixing

- 1) One 20.4 (45 lb) bag of Rapidry DM 50-75 will produce approximately 19 L (5 gal) of Rapidry DM 50-75 mixture. To a clean Dryvit 19 L (5 gal) pail, add 5.2 L (5.5 qt) of clean potable water. As an alternative, on the inside of the Dryvit 19 L (5 gal) pail, draw a horizontal line which measures 97 mm (3 13/16 in) from the base of the pail and fill with water.
- 2) Add the Rapidry DM 50-75 slowly while mixing with a "Twister" paddle or equivalent mixing blade, powered by a 12.7 mm (1/2 in) drill, at 500 - 1200 rpm. **NOTE: A minimum 7 amp drill works best for Portland cement based materials.**
- 3) Thoroughly mix until uniformly wetted, adjusting consistency with a small amount of water or Rapidry DM 50-75 material.
- 4) Let set for five (5) minutes. Retemper, adding a small amount of water if necessary. Material must be free of lumps before using.

b. Mortar Mixer

- 1) Add 5.2 L (5.5 qt) of clean potable water for each 20.4 kg (45 lb) bag of Rapidry DM 50-75 into a clean mortar mixer.
- 2) Add the Rapidry DM 50-75 while the mixer is running. Mix for three to five (3 – 5) minutes, shut the mixer off for 5 minutes, then run mixer for another two to three (2 – 3) minutes to break the set adjusting consistency with a small amount of water or Rapidry DM 50-75. The pot life is approximately 30 minutes depending on temperature.

D. Base Coat only

1. NCB

- a. Open the bucket with a utility knife or lid-off.
- b. Mix NCB to a smooth, homogeneous consistency with a “Twister” paddle or equivalent mixing blade, powered by a 12.7 mm (1/2 in) drill, at 450 - 500 rpm. A small amount of clean potable water may be added to adjust workability.

2. Dryflex

- a. Open the bucket with a utility knife or lid-off.
- b. Due to shipping and storage, there may be some separation of materials. Prior to splitting the material and adding Portland cement, mix the material thoroughly. Use a “Twister” paddle or equivalent mixing blade, powered by a 12.7 mm (1/2 in) drill, at 500 - 1200 rpm. **NOTE: A minimum 7 amp drill works best for Portland cement based materials. CAUTION: Do not over-mix or use other types of mixing blades as air entrapment and product damage may occur and result in workability and performance problems.**
- c. Pour 1/2 of the freshly mixed material [approximately 10.21 kg (22.5 lbs)] into a clean plastic container.
- d. Add 1/4 of a bag [approximately 10.21 kg (22.5 lbs)] of fresh, lump free Type I or II Portland cement. Either gray or white cement is acceptable. Add cement slowly and mix thoroughly. **Do not add large quantities of cement at one time.**
- e. Clean potable water may be added to the mixture to adjust the workability. Add as little water as possible, in small increments, and only after the Portland cement is thoroughly mixed. **Do not over-water as this will degrade the performance and promote efflorescence. NOTE: It is advisable to mix the Dryflex material with Portland cement thoroughly; then wait five (5) minutes and mix again to break the initial set. Retempering with a small amount of water is permissible provided the mixture has not set. The mixture has a pot life similar to any Portland cement material. Mix only as much material as can be conveniently used during a work period.**

E. Primers

1. Color Prime™, Color Prime - W™, Primer with Sand™, and Weatherprime®

- a. Mix material with a “Twister” paddle or equivalent mixing blade, powered by a 12.7 mm (1/2 in) drill, at 450 - 500 rpm to a homogeneous consistency.

F. Finish

1. Quarzputz®, Quarzputz® E, Sandblast®, Freestyle®, Sandpebble®, Sandpebble® E, Sandpebble® Fine, Sandpebble® Fine E, Mojave E™, Weatherlastic® Finishes, and DPR FM™ Finishes.

- a. Thoroughly mix the factory-prepared Dryvit finish with a “Twister” paddle or equivalent mixing blade powered by a 12.7 mm (1/2 in) drill, at 450 - 500 rpm, until a uniform, homogeneous consistency is attained. A small amount of clean potable water may be added to adjust workability. Always add the same amount of water to each pail within a given lot to avoid color variation.

**NOTE: If using a tint pack to color finish please refer to Tint Pack Mixing Instructions, DS750.**

G. Specialty Finishes

1. Ameristone

- a. Mix Ameristone for approximately one (1) minute to ensure uniformity using a “Twister” paddle or equivalent mixing blade powered by a 12.7 mm (1/2 in) drill, at 450 - 500 rpm, just prior to application. **DO NOT OVERMIX.**
- b. Mix all pails for the same amount of time.
- c. If clean potable water is added as described in DS142 for various application techniques, the same amount must be added to each pail.

2. Stone Mist®

- a. Mix Stone Mist for one (1) minute to ensure uniformity using a “Twister” paddle or equivalent mixing blade, powered by a 12.7 mm (1/2 in) drill, 450 - 500 rpm, just prior to application. **DO NOT OVERMIX.**

3. TerraNeo

- a. Mix TerraNeo for one (1) minute just prior to application, to ensure uniformity using a “Twister” paddle or equivalent mixing blade, powered by a 12.7 mm (1/2 in) drill, at 450 - 500 rpm. **DO NOT OVERMIX.**

4. Limestone

- a. Mix Limestone with a “Twister” paddle or equivalent mixing blade, powered by a 12.7 mm (1/2 in) drill, at 450 - 500 rpm until a uniform workable consistency is attained.

**NOTE: If using a tint pack to color finish please refer to Tint Pack Mixing Instructions, DS750.**

5. Custom Brick Finishes

- a. For Custom Brick finishes, refer to Dryvit Custom Brick Application Instructions, DS154, for complete mixing instructions.

**NOTE: If using a tint pack to color finish please refer to Tint Pack Mixing Instructions, DS750.**

6. Reflectit™

- a. Refer to Reflectit Data Sheet DS705 and Application Instructions DS124 for complete instructions.

H. Coatings and Sealers

1. Demandit, Revyvit, Weathercoat™, and Weatherlastic® Smooth
  - a. Mix material with a “Twister” paddle or equivalent mixing blade, powered by a 12.7 mm (1/2 in) drill, at 450 - 500 rpm to a homogeneous consistency.
2. Tuscan Glaze™
  - a. Mix Tuscan Glaze with a “Twister” paddle or equivalent mixing blade, powered by a 12.7 mm (1/2 in) drill, at 450 - 500 rpm to a homogeneous consistency, immediately prior to application. As an alternate, boxing of buckets is acceptable. **Continuously** agitate throughout application to ensure color consistency.
3. SealClear™
  - a. Stir material thoroughly before using and stir often during the application process. As an alternate, boxing of buckets is acceptable.

IV. Rough Opening Preparation Options

A. AquaFlash System Option

1. AquaFlash must be installed to provide a continuous barrier from the air/water-resistive barrier/sheathing substrate onto the framing edges at discontinuities and terminations such as openings, expansion joints, tops of parapets, etc. Refer to Dryvit Outsulation Plus MD System Installation Details, DS110.
2. Surface Preparation
  - a. Apply only when air and surface temperatures are above 4 °C (40 °F).
  - b. The surface to receive the AquaFlash System must be clean, dry, smooth and free of any condition that will hinder adhesion.
  - c. Clean loose dust or dirt from the surface by wiping with a clean, dry cloth or brush.
3. AquaFlash System Application
  - a. Rough Openings (Windows, Doors, Others)
    - 1) Cut AquaFlash Mesh to proper length [rough opening plus 102 mm (4 in)] extending 51 mm (2 in) past each jamb – Figure 1.

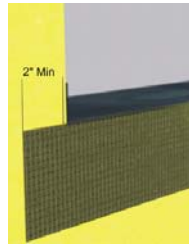

Figure 1

- 2) Begin at the sill of an opening. Using a brush or 19 mm (3/4 in) nap roller, apply a liberal coat of AquaFlash Liquid material to the air/water-resistive barrier/substrate surface. **NOTE: The AquaFlash System must extend to the interior face of the wall opening.**
- 3) Immediately lay the AquaFlash Mesh into the wet material and brush smooth adding additional material to completely embed the mesh - Figure 2.

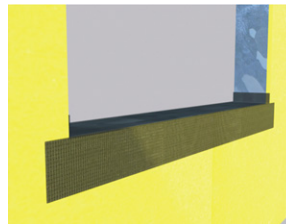

Figure 2

- 4) Install the AquaFlash System at the jambs in the same manner overlapping onto the sill material a minimum of 51 mm (2 in) – Figure 3.

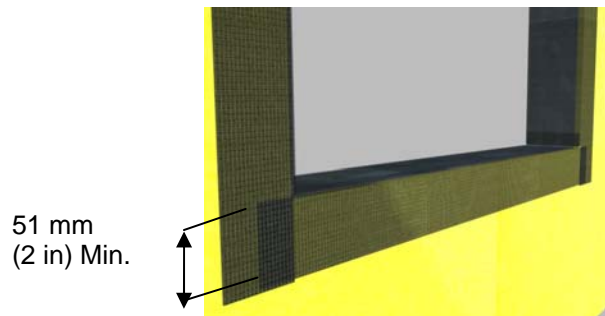
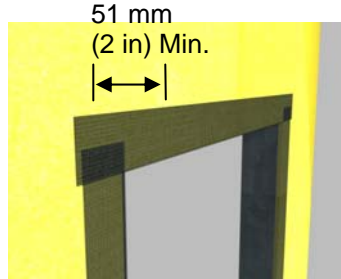

Figure 3

- 5) Install the AquaFlash System at the head overlapping the jamb pieces a minimum of 51 mm (2 in) – Figure 4.



**Figure 4**

- 6) Install diagonal “butterflies” consisting of AquaFlash Liquid and AquaFlash Mesh at each sill/jamb corner – Figure 5.

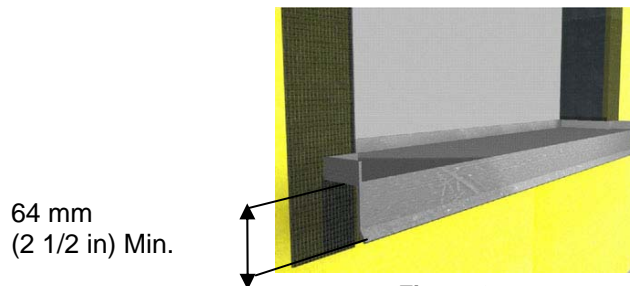

**Figure 5**

- 7) Allow material to set for approximately 15 minutes then apply a second liberal coat of AquaFlash Liquid and smooth out to ensure a continuous film free of voids, pinholes, or other discontinuities.

**4. Sill Pan Flashing (Exposed)**

- a. Install a watertight pan flashing at all sill locations - Figure 6.
- b. The flashing shall extend between the framing members of the rough opening and shall be sized to protect the sill, sheathing and the surface of the Outsulation Plus MD System. It must include vertical legs at the back and sides to ensure proper collection of water. **NOTE: All flashing shall be continuous, have watertight seams, and shall be configured to shed all water to the exterior of the system.**
- c. The flashing shall extend a minimum of 64 mm (2 1/2 in) down over the face of the Outsulation Plus MD System - Figure 6.



**Figure 6**

**5. Sill Pan Flashing (Concealed) for use with nail-on-windows (refer to Dryvit Outsulation Plus MD Installation Details, DS110)**

- a. Install a watertight pan flashing at all sill locations.
- b. The flashing shall extend between the framing members of the rough opening and shall be sized to protect the sill and sheathing. It must include vertical legs at the back and sides to ensure proper collection of water. It shall extend a minimum of 102 mm (4 in) below the opening and have a sloped horizontal leg which continues over the top edge of the Outsulation Plus MD System. **NOTE: All flashing shall be continuous, have watertight seams, and shall be configured to shed all water to the exterior of the system.**

**6. Installation of AquaFlash Over Metal or PVC Flashing Materials**

- a. The AquaFlash System may be applied directly over clean galvanized, painted metal, or PVC flashing.
- b. Prepare rough opening as described in Section IV.A.3.
- c. Install flashing material per contract documents.
- d. Clean the surface of the flashing to ensure that it is free of dirt, dust, oil, or other contaminants that may interfere with adhesion. **NOTE: PVC products should be lightly abraded to break the surface skin and provide tooth for the coating.**

- e. Cut AquaFlash Mesh to proper length [flashing plus 102 mm (4 in) extending 51 mm (2 in) beyond each end of flashing] - Figure 7.

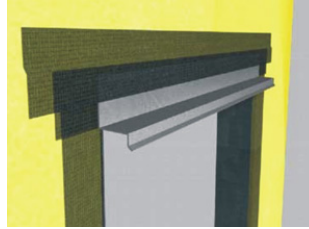

**Figure 7**

- f. Using a brush or 19 mm (3/4 in) nap roller, apply a liberal coat of AquaFlash Liquid material to the flashing and adjacent air/water-resistive barrier/substrate surface.
- g. Immediately lay the AquaFlash Mesh into the wet material and brush smooth adding additional material to completely embed the mesh.
- h. Allow material to set for 15 minutes then apply a second liberal coat of AquaFlash Liquid and smooth out to ensure a continuous film free of voids, pinholes, or other discontinuities and allow to dry.

**B. Dryvit Backstop NT Option**

**1. Surface Preparation**

- a. Apply only when air and surface temperatures are above 4 °C (40 °F).
- b. The surface to receive the Backstop NT must be clean, dry, smooth and free of any other condition that will hinder adhesion.
- c. Remove loose dust or dirt from the surface by wiping with a clean, dry cloth or brush.

**2. Dryvit Backstop NT Application**

**NOTE: Backstop NT may be applied to the sill of the opening but it must also be covered with either the Dryvit AquaFlash System or Dryvit Flashing Tape.**

**a. Rough Openings (Windows, Doors, Others)**

- 1) Apply Dryvit Grid Tape along the jambs and head of the opening as well as all sheathing joints that may intersect the opening and lap onto face of wall a minimum of 51 mm (2 in). Add additional pieces of Grid Tape at the inside corners of the opening to maintain continuity – Figure 8.

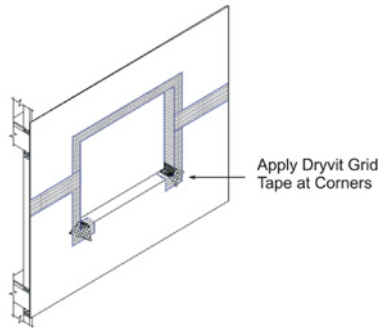

**Figure 8**

- 2) Using a stainless steel trowel apply Backstop NT – Texture over the Grid Tape extending to the inside face of the opening and onto the face of the exterior sheathing a minimum of 152 mm (6 in) – Figure 9.

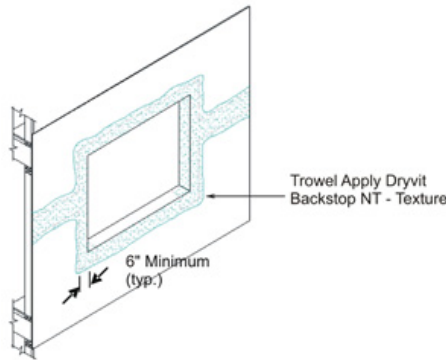

**Figure 9**

- 3) Apply Dryvit AquaFlash System or Flashing Tape at sill in accordance with Sections IV.A.3 and IV.C respectively. **NOTE: AquaFlash System or Flashing Tape must extend up the jambs a minimum of 102 mm (4 in) – Figure 10.**

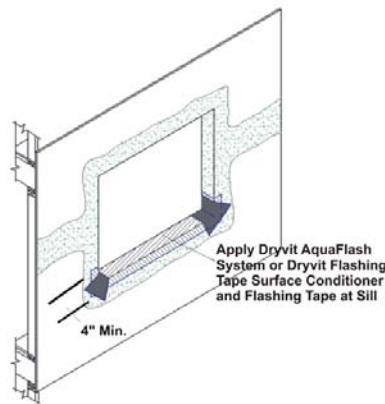

**Figure 10**

- 4) Install the specified component (i.e. window, etc.) and associated flashings per manufacturer’s directions and contract documents. Then apply Backstop NT – Texture or Smooth to the remainder of the wall surface as described in Section VI and lap over the previously installed material (do not lap over Flashing Tape if specified) around openings – Figure 11.

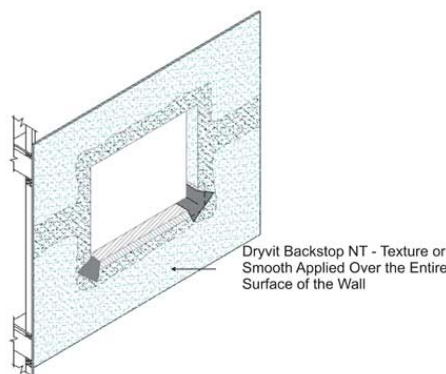

**Figure 11**

**C. Dryvit Flashing Tape Option**

**Caution: The Dryvit Flashing Tape and Surface Conditioner must be handled properly. Refer to the Material Safety Data Sheets for proper handling, storage, health and environmental considerations.**

**NOTE: When Dryvit Flashing Tape is specified for rough opening preparation the air/water-resistive barrier must be installed prior to preparing the opening (see Section VI).**

**NOTE: Coordinate the Dryvit Flashing Tape application with the insulation board installation. Apply only enough Dryvit Flashing Tape that can be covered with the insulation board in the same work period.**

1. Dryvit Flashing Tape must be installed to provide a continuous barrier from the air/water-resistive barrier/sheathing substrate onto the framing edges at discontinuities and terminations such as openings, expansion joints, tops of parapets, etc. Refer to Dryvit Outsulation Plus MD System Installation Details, DS110.
2. Surface Preparation
  - a. Apply only when air and surface temperatures are above 4 °C (40 °F).
  - b. The surface to receive the Dryvit Flashing Tape must be clean, dry, smooth and free of any condition that will hinder adhesion.
  - c. Clean loose dust or dirt from the surface by wiping with a clean, dry cloth or brush.
3. Dryvit Flashing Tape Surface Conditioner Application
  - a. Pour the desired amount of surface conditioner into a clean container to prevent contamination.
  - b. Apply to the surfaces, which are to receive the Dryvit Flashing Tape, using a brush or roller. Sufficient surface conditioner should be applied to condition the surface to a dust free state suitable for the application of the Dryvit Flashing Tape. It should not be applied so heavily that it puddles or runs. Application of excess material will not improve adhesion but will extend the drying time.
  - c. Allow to dry until the surface is slightly tacky. Low temperatures and high humidity conditions may require longer drying times. Conditioning should be limited to areas that can be covered with Dryvit Flashing Tape within the same day.
4. Dryvit Flashing Tape Application
  - a. General
    - 1) Cut the Dryvit Flashing Tape to the appropriate length. Peel the release paper to expose the rubberized asphalt adhesive and align the tape into position before touching the wall.
    - 2) Position the tape on the wall face so that it covers the Backstop NT 51 mm (2 in) and the remainder is turned into the opening.
    - 3) Move along the opening being careful to put the tape as evenly as possible and avoiding fish-mouths along the edges. If wrinkles develop, cut out the affected area and replace.
    - 4) Apply pressure to the tape so that it is firmly in contact with the wall surface. Press the tape into place with a hand roller as soon as possible to ensure continuous and intimate contact with the surface.
    - 5) End laps that occur must maintain a minimum overlap of 51 mm (2 in).
    - 6) Apply Dryvit Flashing Tape so that it completely covers the stud edges extending to the interior face of the opening. Additional strips of Dryvit Flashing Tape may be needed.
    - 7) Cold weather application may require the use of a heat gun to warm the wall surface in order to obtain good initial adhesion.
  - b. Sill/jamb intersections and similar conditions
    - 1) Apply the Dryvit Flashing Tape as shown in the detail below - Figure 12.
    - 2) Apply sill piece first, then apply the corner splice piece. The jamb piece is applied next, lapping over the splice piece.

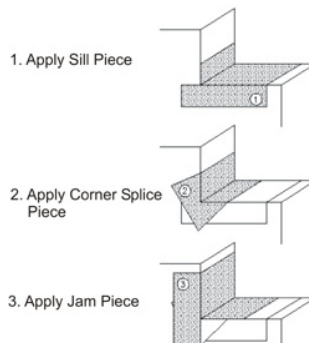

**Figure 12**

- c. Head/jamb intersections
  - 1) The jamb pieces are applied first, followed by the corner splice pieces. The head piece is applied last.
- d. Lap additional pieces of Dryvit Flashing Tape as necessary to cover the returns to the inside edge of the stud or track.

**V. Substrate Expansion Joint Bridging Options**

**A. AquaFlash System Option**

1. Surface Preparation
  - a. Apply only when air and surface temperatures are above 4 °C (40 °F).
  - b. The surface to receive AquaFlash System must be clean, dry, smooth and free of any condition that will hinder adhesion.

- c. Clean loose dust or dirt from the surface by wiping with a clean, dry cloth or brush.
- 2. AquaFlash System Application
  - a. The width of the AquaFlash Mesh must overlap each side of the joint a minimum of 51 mm (2 in) - Figure 13.
  - b. Clean the joint to allow for the installation of a backer material. Install a closed cell polyethylene backer rod sized a minimum of 50% larger than the joint width. Install so that the backer rod is recessed or projects a minimum of 6.4 mm (1/4 in) from the wall surface.

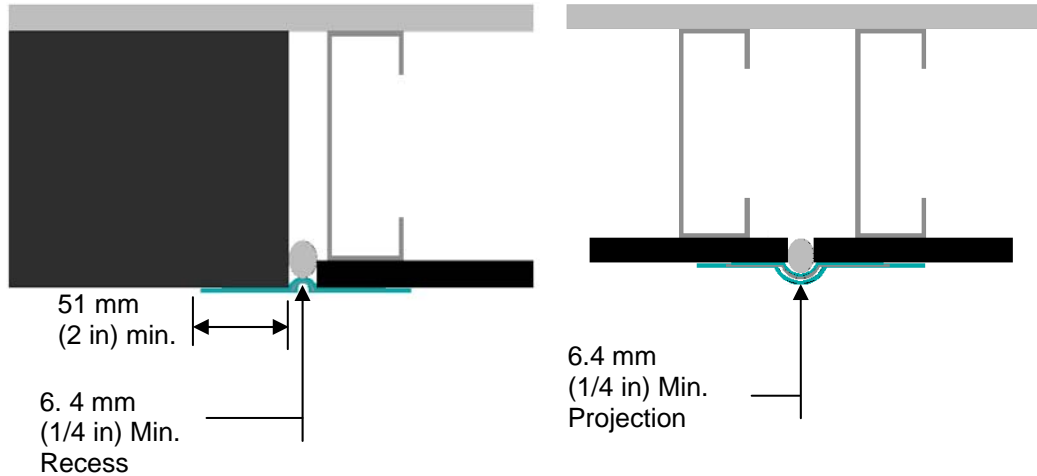

Figure 13

- c. Using a brush or 19 mm (3/4 in) nap roller, apply a liberal coat of AquaFlash Liquid material to the backer rod and adjacent substrate surface to the width of the AquaFlash Mesh - Figure 14.

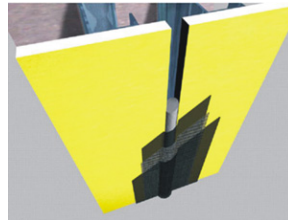

Figure 14

- d. Immediately lay the AquaFlash Mesh into the wet material and brush smooth adding additional material to completely embed the mesh.
- e. Allow material to set for 15 minutes then apply a second liberal coat of AquaFlash Liquid and smooth out to ensure a continuous film free of voids, pinholes, or other discontinuities.
- B. Dryvit Flashing Tape and Flashing Tape Surface Conditioner Option
  - NOTE: When Dryvit Flashing Tape is specified for substrate expansion joint bridging, the air/water-resistant barrier must be installed prior to preparing the joint (see Section VI).**
  - NOTE: Coordinate the Dryvit Flashing Tape application with the insulation board installation. Apply only enough Dryvit Flashing Tape that can be covered with the insulation board in the same work period.**
  - 1. Surface Preparation
    - a. Apply only when air and surface temperatures are above 4 °C (40 °F).
    - b. The surface to receive Dryvit Flashing Tape Surface Conditioner and Dryvit Flashing Tape must be clean, dry, smooth and free of any condition that will hinder adhesion.
    - c. Clean loose dust or dirt from the surface by wiping with a clean, dry cloth or brush.
  - 2. Dryvit Flashing Tape Surface Conditioner Application
    - a. Pour the desired amount of surface conditioner into a clean container to prevent contamination.
    - b. Apply to the surfaces, which are to receive the Dryvit Flashing Tape, using a brush or roller. Sufficient surface conditioner should be applied to condition the surface to a dust free state suitable for the application of the Dryvit Flashing Tape. It should not be applied so heavily that it puddles or runs. Application of excess material will not improve adhesion but will extend the drying time.
    - c. Allow to dry until the surface is slightly tacky. Low temperatures and high humidity conditions may require longer drying times. Conditioning should be limited to areas that can be covered with Dryvit Flashing Tape within the same day.

3. Position the Dryvit Flashing Tape so that it is centered over the joint. Adhere to one side of the joint, and then adhere the adjacent side. Allow enough slack in the tape to account for any joint movement.

#### VI. Air/Water-Resistive Barrier Application

A. When using Backstop DMS refer to DS704

B. Ensure that the wall surface and ambient temperature are above 4 °C (40 °F) and rising at the time of Backstop NT application. **WARNING: Do not apply the Dryvit materials in the rain. The underlying wall materials and substrate surface must be dry prior to applying the air/water-resistive barrier.**

C. Sheathing Substrates

1. Prior to applying the Backstop NT over a sheathing substrate, check to ensure that:

- a. The sheathing is of a type listed in the Outsulation Plus MD System Specification, DS137.
- b. The sheathing is structurally sound, free of loose material, voids, projections or other conditions that may interfere with the installation of the Outsulation Plus MD System.
- c. The sheathing is clean, dry, and free of grease, oil, paint and other foreign material.

1) Exterior grade gypsum sheathing facing paper shall not show signs of deterioration and shall be firmly bonded to the core.

2) Plywood or OSB moisture content shall not exceed 19% as measured by a probe type moisture meter.

d. There are no planar irregularities greater than 6.4 mm (1/4 in) within any 1.2 m (4 ft) radius. **SHEATHING WITH GAPS OR DAMAGE EXCEEDING 6.4 mm (1/4 in) IN ANY ONE DIRECTION MUST BE REPLACED.**

**NOTE: Notify the general contractor and/or architect and/or owner of all discrepancies. Do not proceed until all unsatisfactory conditions have been corrected.**

**NOTE: OSB sheathing requires that joints and fasteners be treated with Backstop NT - Texture. A minimum of two (2) coats of Backstop NT - Smooth are required for the field of the wall.**

**Backstop NT - Texture is not recommended for application in the field of the board.**

D. Concrete or Masonry Substrates

**NOTE: Backstop NT - Texture is the only recommended product use over concrete and masonry.**

1. Prior to applying the Backstop NT - Texture over a concrete or masonry substrate, check to ensure that:

- a. All cracks are repaired using appropriate procedures and materials.
- b. The substrate is structurally sound, free of loose material, voids, projections or other conditions that may interfere with the installation of the Outsulation Plus MD System.
- c. The substrate is clean, dry, free of grease, oil, paint, form release agents, efflorescence and other foreign materials that may inhibit adhesion.
- d. There are no planar irregularities greater than 6.4 mm (1/4 in) within any 1.2 m (4 ft) radius.

1) **Mortar joints that are NOT struck flush or heavily textured masonry units shall be skim coated with Dryvit Genesis or Genesis DM prior to the application of Backstop NT - Texture.**

a) Mix Genesis or Genesis DM in accordance with Section III.C.1 or III.C.3, respectively.

b) With a stainless steel trowel, apply a coat of the Genesis mixture or Genesis DM mixture over the substrate to fill the mortar joints and surface texture to provide a uniform smooth surface for the application of the Backstop NT - Texture.

c) Allow the skim coat to completely dry prior to applying the Backstop NT - Texture.

E. Usage Application Chart

Backstop NT - Texture and Backstop NT - Smooth Usage/Application Chart				
Substrate	Location	Product	Tool	Approximate Coverage Per Pail <sup>e</sup>
Exterior Grade Gypsum Sheathing	Joints <sup>a</sup>	Backstop NT - Texture	Trowel	91 m (300 lin. ft.)
	Face <sup>f</sup>	Backstop NT - Texture OR	Trowel or FoamPRO #58 Roller <sup>b</sup>	For both tools 23-28 m <sup>2</sup> (250-300 ft <sup>2</sup> )
		Backstop NT - Smooth	12.7 mm (1/2 in) Nap Roller	46 m <sup>2</sup> (500 ft <sup>2</sup> ) <sup>c</sup>
Fiberglass Faced Exterior Gypsum Sheathing	Joints <sup>a</sup>	Backstop NT - Texture	Trowel	91 m (300 lin. ft.)
	Face <sup>f</sup>	Backstop NT - Texture OR	Trowel	23-28 m <sup>2</sup> (250-300 ft <sup>2</sup> ) [includes joints]
		Backstop NT - Smooth	19 mm (¾ in) Nap Roller	37 m <sup>2</sup> (400 ft <sup>2</sup> ) <sup>c</sup>
Exterior Grade and Fire Retardant Treated Plywood and Exterior Cement Board	Joints <sup>a</sup>	Backstop NT - Texture	Trowel	91 m (300 lin. ft.)
	Face <sup>f</sup>	Backstop NT - Texture OR	Trowel or FoamPRO #58 Roller <sup>b</sup>	For both tools 23-28 m <sup>2</sup> (250-300 ft <sup>2</sup> )
		Backstop NT - Smooth	12.7 mm (1/2 in) Nap Roller	37 m <sup>2</sup> (400 ft <sup>2</sup> ) <sup>c</sup>
APA Exposure 1 Rated Oriented Strand Board (OSB)	Joints <sup>a</sup>	Backstop NT - Texture	Trowel	91 m (300 lin. ft.)
	Face	Backstop NT - Smooth	12.7 mm (1/2 in) Nap Roller	33-37 m <sup>2</sup> (350-400 ft <sup>2</sup> ) applied in 2 coats
Concrete and Masonry <sup>d</sup>	Face	Backstop NT - Texture	Trowel <sup>g</sup>	16.7 m <sup>2</sup> (180 ft <sup>2</sup> ) <sup>h</sup>
			FoamPRO #58 Roller <sup>b</sup>	11-14 m <sup>2</sup> (125-150 ft <sup>2</sup> ) <sup>h</sup> applied in 2 coats

<sup>a</sup> Tape the joints with Dryvit Grid Tape prior to application of Backstop NT - Texture at joints and screw heads.

<sup>b</sup> Up to 1 pint (16 oz) of water may be added to a 60 lb pail of Backstop NT - Texture for roller or spray applications only. The FoamPRO #58 roller cover (FoamPRO Mfg., Inc., www.foampromfg.com) is available at home supply stores.

<sup>c</sup> Because of application methodology and absorptive surface differences, two coats may be required to obtain this coverage.

<sup>d</sup> Apply a 6 ft x 6 ft test area with coverage as indicated in the chart, before proceeding with the entire job. If there are voids in the dried BSNT - Texture, particularly at the mortar joints, the job should be parged with Genesis, 24 hours prior to BSNT - Texture roller application.

<sup>e</sup> Backstop NT - Texture and Smooth should be applied at the recommended coverage rates to form a continuous film free of voids at a dry film thickness of approximately 12 mils.

<sup>f</sup> Backstop NT - Texture (with up to 1 pint water addition per 60 lb. pail) or Smooth may be sprayed and backtrowelled/backrolled.

<sup>g</sup> Due to variations in types of masonry a 6 ft x 6 ft test area shall be prepared to ensure that a continuous film can be achieved. **Backstop NT shall NOT be used as a skim coat for parging joints or heavy textured units.**

<sup>h</sup> Coverage may vary depending on the porosity of the masonry substrate. Coverage based on smooth, dense block surface.

F. Application of Backstop NT

1. Dryvit Grid Tape (not required with concrete and masonry substrates)

- a. For sheathing substrates, apply the Dryvit Grid Tape along all joints in the sheathing, as well as inside corners, outside corners, and exposed edges at terminations that will not be covered with Dryvit AquaFlash or Dryvit Flashing Tape.
- b. Center the Dryvit Grid Tape on the sheathing joints, edges, etc. with the pressure sensitive adhesive backing in contact with the sheathing surface. Press into position with hand pressure until adhesion is achieved.
- c. Apply only enough Dryvit Grid Tape as can be covered with Backstop NT - Texture in the same day.

2. Dryvit Backstop NT - Texture Application

**NOTE: Backstop NT Texture is NOT recommended for use over the face of OSB.**

- a. General: Backstop NT - Texture can be applied using a roller, trowel or spray equipment over the listed substrates, as noted in the usage chart above. Backstop NT - Texture should be applied at the recommended coverage rate to achieve a continuous film at a minimum dry film thickness of approximately 0.3 mm (12 mils).

b. Roller Application

- 1) Apply Dryvit Grid Tape as described in Section VI.F.1 above. Mix the Backstop NT - Texture material as described in Section III.B.2. Using a stainless steel trowel or spatula, apply a layer of Backstop NT - Texture over the Dryvit Grid Tape and spot all fastener heads – Figure 15. **NOTE: Dryvit Grid Tape is not necessary over fastener heads.**

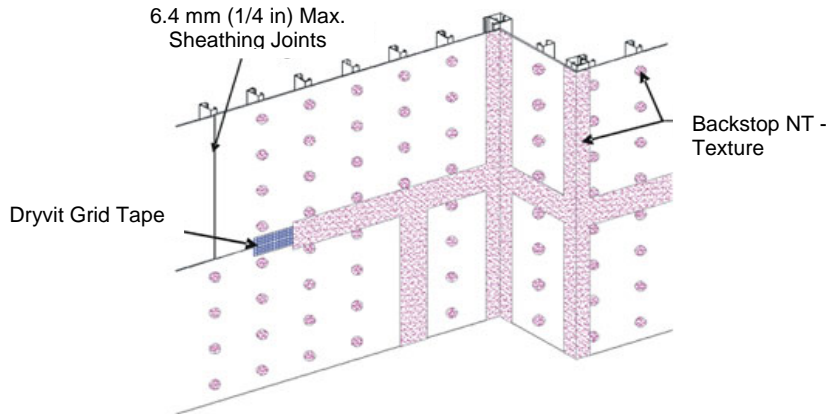

Figure 15

- 2) Allow to dry for a minimum of 2 hours or until dry to the touch. **NOTE: Cool, humid conditions may require longer drying times**

- a) Because of the absorption characteristics, plywood substrates may require a second pass to fill any voids at the sheathing joints. After the first pass has dried, check the joints and spot any voids that may be present with additional Backstop NT – Texture material and allow to dry.

- 3) Use a coarse, open-cell foam roller cover with a 9.5 mm (3/8 in) foam nap (FoamPRO #58 roller). Apply a uniform, continuous film of Backstop NT – Texture over the entire surface of the sheathing, concrete or masonry, including the previously treated areas – Figure 16. **NOTE: If the roller pulls material back out of the sheathing joints, it indicates that the joint material is not sufficiently dry.**

- a) For concrete and masonry, ensure that a continuous film of uniform thickness is applied across the entire surface and across mortar joints. Minimum 2 coats are required allowing a minimum of 2 hours between coats. Cool, damp weather may require longer time between coats.

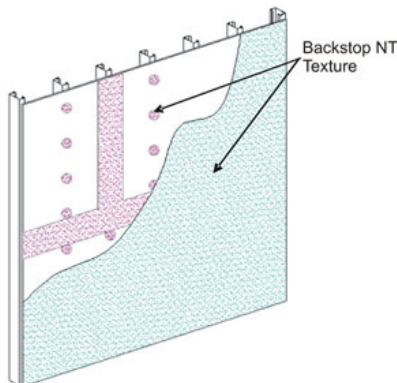

Figure 16

- 4) While the Backstop NT - Texture is still wet, using a trowel or spatula, smooth out the Backstop NT - Texture around all window and door perimeters and other areas that will later receive Dryvit Flashing Tape - Figure 17.

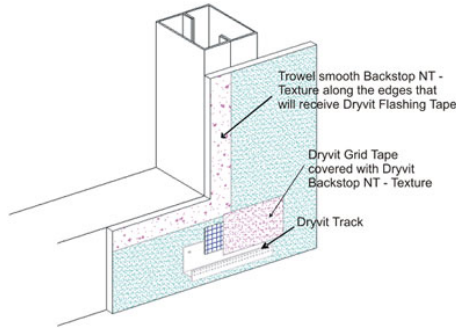

Figure 17

- 5) The Backstop NT - Texture material should be applied in a uniform, continuous film at the recommended coverage rate. **NOTE: Substrates with a surface texture or high porosity will require additional material.**
- c. Trowel Application
- 1) Apply Dryvit Grid Tape as described in Section VI. F.1 above. Mix the material, as described in Section III.B.2, and using a stainless steel trowel or spatula, apply a layer of Backstop NT – Texture over the grid tape. Spotting of fasteners is not necessary when applying Backstop NT - Texture using a trowel. Allow to dry for a minimum of 2 hours or until dry to the touch.
  - 2) Using a stainless steel trowel, apply a continuous coating of Backstop NT - Texture material onto the entire surface. The material should be applied at a smooth, uniform, continuous film approximately equal to the thickness of the aggregate.
- d. Spray/Back-Rolling Application
- 1) Apply Dryvit Grid Tape as described in Section VI. F.1 above. Mix the material as described in Section III.B.2 and using a stainless steel trowel or spatula, apply a layer of Backstop NT - Texture over the grid tape and spot all fastener heads. Allow to dry for a minimum of 2 hours or until dry to the touch.
  - 2) Because of the absorption characteristics, plywood substrates may require a second pass to fill any voids at the sheathing joints. After the first pass has dried, check the joints and spot any voids that may be present with additional Backstop NT - Texture material and allow to dry.
  - 3) Using a hand held hopper gun or other suitable spray equipment; spray a layer of Backstop NT - Texture onto the wall surface. Using a coarse, open-cell foam roller cover with a 9.5 mm (3/8 in) foam nap (FoamPro #58 roller), roll the material to create a smooth continuous film. **NOTE: If the roller pulls material back out of the sheathing joints, it indicates that the joint material is not sufficiently dry.**
  - 4) While Backstop NT - Texture is still wet, using a trowel or spatula, smooth out the Backstop NT - Texture around all window and door perimeters and other areas that will later receive Dryvit Flashing Tape – Figure 17.
  - 5) Backstop NT - Texture material should be applied in a uniform, continuous film at the recommended coverage rate. **NOTE: Substrates with a surface texture or high porosity will require additional material.**
- e. Allow the Backstop NT – Texture to completely dry prior to installation of the Outsulation Plus MD System
3. Backstop NT - Smooth Application
- a. General: Dryvit Backstop NT - Smooth can be applied using a roller or sprayed and back-rolled over the acceptable sheathing substrates. **NOTE: OSB sheathing requires that joints and fasteners be treated with Backstop NT - Texture. A minimum of two (2) coats of Backstop NT - Smooth are required for the field of the wall. Backstop NT - Texture is not recommended for application in the field of the board.**
  - b. Sheathing Substrates: All fastener heads shall be spotted and joints treated with Backstop NT - Texture and Dryvit Grid Tape prior to Backstop NT -Smooth application, in accordance with Section VI. F.2.
  - c. Roller Application
    - 1) Using the appropriate nap roller (see Usage Application Chart), apply the Backstop NT - Smooth over the entire wall surface, including previously treated joints. **NOTE: If the roller pulls material back out of the sheathing joints, it indicates that the joint material is not sufficiently dry.**

- 2) Backstop NT - Smooth material should be applied in a uniform, continuous film at the recommended coverage rate. **NOTE: Sheathing substrates with a surface texture or high porosity will require additional material.**

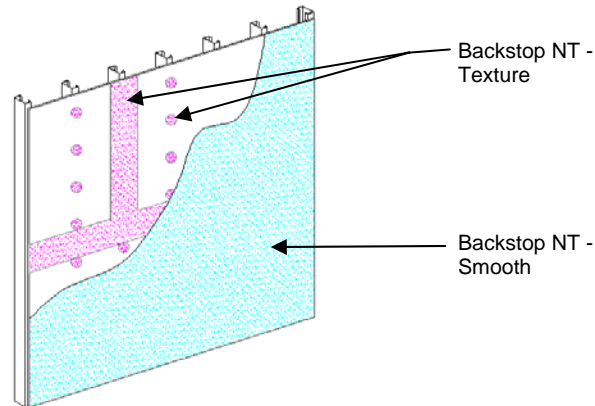

Figure 18

d. Spray/Back-Rolling Application

- 1) Backstop NT - Smooth may be applied to the wall using spray equipment and back-rolled using the appropriate nap roller (see Usage Application Chart).
  - 2) Allow the Backstop NT – Smooth to completely dry, check the wall to ensure that the Backstop NT - Smooth is continuous and touch up any visible voids with additional Backstop NT - Smooth material.
- e. Allow the Backstop NT – Smooth to completely dry prior to installation of the Outsulation Plus MD System.

**VII. Accessories**

A. Installation of the Dryvit Drainage Strip or Drainage Track

1. Dryvit Drainage Strip (Optional - not required when Drainage Track is specified)

- a. Dryvit Drainage Strip shall be used at the base of the walls and shall be installed at the heads of all penetrations and at expansion/control joints as shown in Outsulation Plus MD Installation Details, DS110.
- b. Using a chalk line, strike a level line at the base of the wall, head of opening or expansion/control joint to use as reference in applying the Dryvit Drainage Strip.
- c. Install the Dryvit Drainage Strip by applying dabs of Dryvit's AP Adhesive at 305 mm (12 in) on center on the dry Backstop NT air/water-resistive barrier.
- d. Position the Dryvit Drainage Strip on the chalk line and press firmly against the substrate to ensure firm contact between the adhesive and the wall surface. Staples or other fasteners may be used if necessary to maintain position until the insulation board is installed.

2. Dryvit Drainage Track (Optional - not required when Drainage Strip is specified)

- a. Dryvit Drainage track usage is limited to the base of the system at finished grade level.
- b. Using a chalk line, strike a level line at the base of the wall that coincides with either the top or bottom of the nailing flange.
- c. Install the Dryvit Drainage Track by applying a continuous horizontal bead of Dryvit's AP Adhesive on the wall side of the track's nailing flange.
- d. Position the track on the chalk line and press firmly against the substrate to ensure firm and continuous contact between the adhesive and the wall surface. **NOTE: Do not overlap tracks, they shall be butted tightly.**
- e. Secure the track to the wall using corrosion resistant fasteners attached into the underlying framing members. **NOTE: It is recommended that the surface of the Drainage Track be lightly sanded to improve adhesion of Backstop NT or AquaFlash.**
- f. Install the AquaFlash System, Backstop NT and Grid Tape or Flashing Tape on the flange of the Drainage Track and the adjacent wall in order to ensure water-tightness at the flange/wall interface. See Section IV for proper application.

**VIII. Insulation Board Installation**

A. When using Backstop DMS refer to DS704

B. System Terminations

1. Attach Detail Mesh around the perimeter of all openings, penetrations, and other system terminations by stapling or applying a ribbon of adhesive mixture on the substrate and embedding the Detail Mesh into the wet mixture.  
**NOTE: Back wrapping is not required at the base of the wall when using the Dryvit Drainage Track.**
2. Position the Detail Mesh so that a minimum of 64 mm (2 1/2 in) will extend onto the face of the insulation board. Keep the mesh, which is not embedded, clean.

C. Inspection of the Insulation Board

1. Prior to installing the insulation board, it shall be checked to ensure that:
  - a. It is shipped in a clear polyethylene bag bearing the Dryvit name. In addition, the lot number of the insulation board shall be visible on the outside of the bag. Insulation board shall be obtained from Dryvit Systems, Inc. or its authorized distributors, and made exclusively by manufacturers listed by Dryvit Systems, Inc.
  - b. One edge of each board shall bear the word Dryvit, the plant identification number of the block molder, the appropriate model code report number, and the name of the third party quality control agency with corresponding number. In addition, one board in each bag shall bear the same markings on the face.
  - c. The insulation board measures a maximum of 0.6 m (2 ft) by 1.2 m (4 ft) with a minimum thickness of 19 mm (3/4 in).
  - d. The insulation board meets the following tolerances:
    - 1) Length: Plus or minus 1.6 mm (1/16 in).
    - 2) Width: Plus or minus 1.6 mm (1/16 in).
    - 3) Thickness: Plus or minus 1.6 mm (1/16 in) for boards greater than 25 mm (1 in), plus 1.6 mm (1/16 in) minus 0 for boards less than or equal to 25 mm (1 in).
    - 4) Squareness: Shall not deviate from square by more than 0.8 mm (1/32 in) in 305 mm (12 in) of total length or width.
    - 5) Edge Trueness: Shall not deviate more than 0.8 mm (1/32 in) in 305 mm (12 in).
    - 6) Face Flatness: Shall not exhibit any bowing of more than 0.8 mm (1/32 in) in the length.

**WARNING: Any insulation board not meeting the above requirements should be rejected and not installed.**

D. Methods of Applying the Dryvit Adhesive

1. Mix the Dryvit adhesive in accordance with Section III.C

a. Cementitious Adhesive

1) Notched Trowel Method

- a) With a notched trowel, 9.5 mm (3/8 in) wide, 12.7 mm (1/2 in) deep notches spaced 38 mm (1 1/2 in) apart, apply the adhesive mixture to the backside of the insulation board. Holding the trowel at a 45° angle, apply firm pressure to the insulation board in order to scrape the excess adhesive from between the adhesive beads. **NOTE: Apply the adhesive so that the ribbons run vertically when the insulation board is placed on the wall.**

2) Ribbon and Dab Method

- a) Using a stainless steel trowel, install a ribbon of the adhesive mixture, 51 mm (2 in) wide by 9.5 mm (3/8 in) thick around the entire perimeter of the insulation board. Place eight (8) dabs of the adhesive mixture 9.5 mm (3/8 in) thick by 102 mm (4 in) in diameter approximately 203 mm (8 in) on center to the interior area of the insulation board. **NOTE: The ribbon and dab method of applying the adhesive mixture shall not be used, nor is it recognized by the building codes when applying the Outsulation Plus System over a sheathing substrate. Installations over a sheathing substrate shall use the notched trowel method described above.**

3) Push Box Method

- a) A push box may also be used to install the adhesive mixture on the insulation board. Contact Dryvit Systems, Inc. for complete details for construction of a push box. **NOTE: Apply the adhesive so that the ribbons run vertically when the insulation board is placed on the wall.**

b. Non-cementitious Adhesive

- 1) AP Adhesive - recommended for use in limited areas only, such as metal surfaces, including steel lintels, metal flashing, etc.
  - a) Cut the smallest opening possible in spout (just large enough so adhesive can flow easily when gunned). It is intended to be applied in thin beads [approximately 9.5 mm (3/8 in)].

2. When using Backstop DMS refer to DS704

E. Insulation Board Installation

1. Prior to installing the insulation board, ensure that the surface of the Backstop NT is uniform in thickness, continuous, clean, dry and free of any foreign materials that will affect adhesion of the insulation board.
2. Begin installation of the insulation board from a permanent or temporary support.
3. When sheathing is used as a substrate, use a 305 mm (12 in) high by 1.2 m (4 ft) long piece of insulation board as a starter row at the base of the wall. This will help minimize the insulation board joints from coinciding with

the sheathing joints. Offset the insulation board joints from the sheathing joints a minimum of 203 mm (8 in) in both vertical and horizontal directions. Install the insulation boards with their long edges oriented horizontally.

4. Apply the adhesive to the insulation board as described in Section VIII.D.
  - a. When using Primus, Genesis, Primus DM, Genesis DM, Genesis DMS or Genesis FM as the adhesive, butter the edge of the insulation board at all terminations in order to properly embed the previously installed Detail Mesh used for back wrapping. Back wrapping is necessary to provide appropriate fire performance and to create the proper surface for application of sealant. **NOTE: The application of the adhesive mixture to the edge of the insulation board is only done when wrapping with the Detail Mesh.**
  - b. Genesis DMS may be applied to the substrate surface in a vertical notched trowel pattern as described in Section VIII.D.1.a.1). Refer to Genesis DMS Data Sheet, DS471.
5. Position the insulation board horizontally on the substrate. Press the board gently to the substrate and slide it into position. Apply firm pressure over the entire surface of the insulation board to ensure uniform contact and high initial grab.
6. Using a margin trowel, clean the insulation board edges of any adhesive mixture. Ensure that the insulation board joints are butted tightly and faces are level and flush. **CAUTION: Do not allow adhesive to remain in board joints.**
7. Install subsequent rows of insulation board in a running bond pattern (vertical joints staggered).
8. With factory edges exposed, stagger vertical joints at inside and outside corners. Make sure the corners are straight and plumb.
9. To ensure an overall flat surface, tamp the insulation board surface with a board that overlaps two to four rows of insulation.
10. If for any reason the insulation board joints are not butted tightly, slivers of insulation board must be installed to fill any gaps. ALL GAPS GREATER THAN 1.6 mm (1/16 in) MUST BE SLIVERED. **Tip: In order to create a tight fit, it is recommended that a wider joint be cut with a hot groove or similar tool to allow for a more precise fitting sliver. Do not install adhesive on sliver edges.**
11. Windows, Doors, Mechanical Equipment and all Wall Penetrations
  - a. Option 1
    - 1) At openings, align the insulation boards so that the edges (vertical and horizontal joints) do not coincide with the corners of the opening (refer to Dryvit Outsulation Plus MD System Installation Details, DS110).
    - 2) Attach Detail Mesh around the perimeter of the opening as described in Section VIII.B.
    - 3) Hold the insulation board back from the window/door frame or mechanical equipment to allow for differential movement, proper system edge preparation, and sealant installation as shown in the Dryvit Outsulation Plus MD System Installation Details, DS110.
  - b. Option 2 - Installation of J Track at heads of all openings [length not to exceed 0.3 m (10 ft)]. **Tip: It is recommended to use a 19 mm (3/4 in) casing bead as manufactured by Plastic Components – item numbers 1075 or CB 75-25.**
    - 1) Because insulation board joints cannot align with corners of openings, first cut L-shaped pieces of insulation board for the corners of the opening. Then measure and cut the insulation board to the proper length to fit between the corner pieces over the opening. Insulation board shall be notched to receive J track as shown in the Dryvit Outsulation Plus MD System Installation Details, DS110.
    - 2) Mix the adhesive material as described in Section III.C.
    - 3) Cut the Detail Mesh to a working length.
    - 4) Apply a ribbon of adhesive mixture on the air/water-resistive barrier/substrate and position the Detail Mesh in the wet mixture allowing for a 64 mm (2 1/2 in) minimum overlap onto the face of the insulation board. Keep the mesh, which is not embedded, clean.
    - 5) Apply the adhesive mixture to the backside of the insulation board in accordance with Section VIII.D and position on the wall. Press gently and slide into position applying uniform pressure to ensure full contact and high initial grab.
    - 6) Using a margin trowel, remove any adhesive from the edges of the insulation boards that will abut other insulation boards. **CAUTION: Do not allow adhesive to remain in board joints. Ensure that the insulation board joints are abutted tightly, and are level and flush.**
    - 7) Measure and cut J Track so that it extends 152 mm (6 in) beyond the edges of the opening as shown in Outsulation Plus MD Installation Details DS110.
    - 8) Install the J Track by applying a continuous bead of Dryvit AP Adhesive on the wall side of the vertical nailing flange of the track and position over the notched insulation board. Press firmly against the substrate to ensure firm and continuous contact between the adhesive and the wall surface.
    - 9) Secure the track to the wall using corrosion resistant fasteners attached into the underlying framing members. **NOTE: It is recommended that the surface of the track be lightly sanded to improve adhesion.**
    - 10.) Install the AquaFlash System, Backstop NT and Grid Tape or Flashing Tape on the flange of the J Track and the adjacent wall in order to ensure water-tightness at the flange/wall interface. See Section IV for proper application.

12. Expansion Joints
  - a. Attach Detail Mesh around the perimeter of the opening as described in Section VIII.B.
  - b. When abutting dissimilar materials, leave a minimum 19 mm (3/4 in) separation between the insulation board and abutting material to allow for differential movement, proper system edge preparation and sealant installation.
  - c. When the Outsulation Plus MD System is installed at a substrate transition, leave a minimum 19 mm (3/4 in) separation between the insulation boards to allow for differential movement, proper system edge preparation and sealant installation.
13. **IMPORTANT:** Once the insulation board and Detail Mesh are in place, wait a minimum of 24 hours prior to working on the surface of the insulation board to prevent any movement which may weaken the bond of the adhesive mixture to the substrate. **NOTE: Be sure to protect the installed insulation board from rain, freezing or inclement weather for a period of 24 hours.**
14. Any irregularities in the insulation board surface must be sanded flat. Sanding is accomplished with a light circular motion. **The entire wall area must be sanded.** Use grade 20 grit sandpaper or coarser, in conjunction with hand, electric or air rasps. **NOTE: Do not sand parallel to the insulation board joints.** **CAUTION: The contractor shall take precautions to contain EPS dust from rasping operation in accordance with contract documents. Use of vacuum rasps are recommended to minimize introduction of EPS dust into the environment.**
15. Remove all loose pieces of insulation board and dust from the sanding operation using a brush, broom, or compressed air. Use OSHA required masks to protect against inhaling EPS dust.
16. All Detail Mesh that was previously installed for back wrapping the insulation board shall be embedded in the base material mixture at this time.
  - a. With a stainless steel trowel, apply any of Dryvit's cementitious base material mixture to the face (and edge if not previously coated) of the insulation board and embed the Detail Mesh in the wet mixture. **NOTE: It is not recommended to use NCB to embed reinforcing mesh at EPS edges that will receive sealant.**
17. Aesthetic Reveals
  - a. To install an aesthetic reveal, snap a straight line using a chalk line to mark the position.
  - b. Position a straight edge such as a steel stud or track against the insulation board in the proper location to guide the appropriate cutting tool (router, hot knife, or hot groover). **CAUTION: The thickness of the insulation board in the bottom of the reveal must not be less than 19 mm (3/4 in).**
  - c. Use Detail Mesh to ensure continuity of reinforcing mesh through aesthetic reveals continuing a minimum of 64 mm (2 1/2 in) on each side of the reveal.
    - 1) Apply the base material mixture in the reveal and on the adjacent insulation board surfaces.
    - 2) Embed the Detail Mesh into base coat mixture on one side of the reveal only.
    - 3) Use a sled or special tool configured to the profile of the reveal. Embed the Detail Mesh into the base coat mixture through the reveal being careful not to cut the mesh.
    - 4) Embed the Detail Mesh into the base coat mixture on the other side of the reveal. Ensure that the mesh is fully embedded and that all excess material is removed from the reveal.
    - 5) Using a damp brush, smooth out any irregularities in the base coat.**CAUTION: If the mesh is cut in the reveal, a new piece of mesh must be installed over the cut.**
18. Where Corner Mesh is specified for additional impact resistance at outside corners, the Corner Mesh shall be embedded in the base coat mixture and allowed to set prior to installing the overall reinforced base coat over the face of the wall.
19. Corners of all openings such as windows, doors, mechanical equipment and all penetrations shall be reinforced with Detail Mesh placed diagonally to the opening as illustrated in Figure 19.

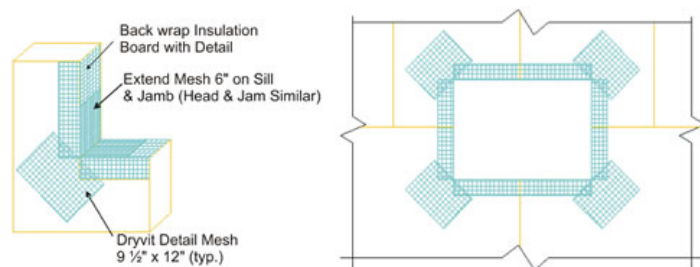

Figure 19

**IX. Installation of Reinforcing Mesh and Base Coat**

A. General

1. **Do not apply the Dryvit materials in the rain. The insulation board must be dry prior to applying the base coat material.**
2. Prior to installing the reinforced base coat, inspect the surface of the insulation board for:

- a. Flatness: Use a minimum 2.4 m (8 ft) straight edge. Sand any high areas and out-of-plane board joints flat, as described in Section VIII.E.14 and 15. **CAUTION: Do not build up low areas with base coat mixture to form a flat surface.**
  - b. Damage and foreign materials: correct deficiencies as necessary.
  - c. Surface degradation due to weathering or UV, visible as discoloration. Sand affected areas to remove deterioration while maintaining the flatness of the surface.
- B. Mix the base coat material as described in Section III.C and D.
- C. Prior to installing the reinforcing mesh, it should be inspected to ensure that it has been furnished by Dryvit Systems, Inc.
- 1. Dryvit reinforcing mesh is available in the following widths and lengths:
    - a. Standard - 1.2 m x 45.7 m (48 in x 150 ft); 1.8 m x 45.7 m (72 in x 150 ft)
    - b. Standard Plus, and Intermediate - 1.2 m x 45.7 m (48 in x 150 ft)
    - c. Panzer 15 - 1.2 m x 22.9 m (48 in x 75 ft)
    - d. Panzer 20 - 1.2 m x 22.9 m (48 in x 75 ft)
    - e. Corner - 235 mm x 45.7 m (9 1/4 in x 150 ft)
    - f. Detail - 241 mm x 45.7 m (9 1/2 in x 150 ft)
  - 2. It shall be colored blue for product identification bearing the Dryvit logo.
- D. Installation of Dryflex base coat in high exposure areas such as sloped surfaces, window sills, etc.
- 1. Using a stainless steel trowel, apply the Dryflex mixture on the surface of the insulation board in a uniform thickness of approximately 2.4 mm (3/32 in). Apply the Dryflex continuously over the sloped surface and continue minimum 152 mm (6 in) onto the vertical areas.
  - 2. Immediately place the reinforcing mesh against the wet Dryflex mixture. With the curve of the mesh against the wall, trowel from the center to the edges, avoiding wrinkles, until the mesh is fully covered and not visible. The overall minimum base coat thickness shall be sufficient to **fully embed** the reinforcing mesh. The recommended method is to apply the base coat in two (2) passes.
- NOTE: The reinforcing mesh can be continued across the transition from Dryflex base coat to standard base coat.**
- 3. Allow the Dryflex to cure a minimum of 24 hours or until dry.
- E. Base Coat Application
- 1. Standard Base Coat (single layer of Standard, Standard Plus or Intermediate Reinforcing Mesh)
    - a. The base coat shall be applied such that the resulting overall minimum base coat thickness is sufficient to **fully embed** the reinforcing mesh. The recommended method is to apply the base coat in two (2) passes.
    - b. Double pass method (recommended)
      - 1) Using a stainless steel trowel, apply the base coat mixture on the entire surface of the insulation board to an area slightly larger than the width and length of a piece of reinforcing mesh, in a uniform thickness of 1.6 mm (1/16 in). **NOTE: The reinforcing mesh may be installed either vertically or horizontally.**
      - 2) Immediately place the reinforcing mesh against the wet base coat mixture. With the curve of the mesh against the wall, trowel from the center to the edges avoiding wrinkles, until the mesh is fully embedded and not visible. Trowel smooth to a uniform thickness slightly more than the thickness of the reinforcing mesh. **NOTE: The reinforcing mesh shall be continuous at corners and mesh edges lapped not less than 64 mm (2 1/2 in). Do not lap the reinforcing mesh within 203 mm (8 in) of a corner. Tip: Corners and edges normally require light strokes with a small damp brush to smooth out irregularities.**
      - 3) Allow the base coat mixture to take up until firm to the touch. Trowel a second tight coat of the base coat mixture over the first coat to **fully cover** the reinforcing mesh - Figure 20. The result should be such that the reinforcing mesh is approximately centered within the base coat thickness. Do not allow the first pass to completely dry prior to the second pass application or an excessive amount of base coat mixture will be necessary to fully coat the wall surface.

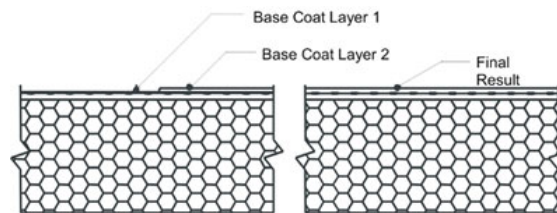

**Figure 20**

- c. Single pass method (optional)
  - 1) Using a stainless steel trowel, apply the base coat mixture on the entire surface of the insulation board to an area slightly larger than the width and length of a piece of reinforcing mesh, in a uniform thickness of 1.6 mm (1/16 in). **NOTE: The reinforcing mesh may be installed either vertically or horizontally.**

- 2) Immediately place the reinforcing mesh against the wet base coat mixture. With the curve of the mesh against the wall, trowel from the center to the edges avoiding wrinkles, until the mesh is fully embedded and not visible. Trowel smooth to a uniform thickness slightly more than the thickness of the reinforcing mesh.  
**NOTE: The reinforcing mesh shall be continuous at corners and mesh edges lapped not less than 64 mm (2 1/2 in). Do not lap the reinforcing mesh within 203 mm (8 in) of a corner. Tip: Corners and edges normally require light strokes with a small damp brush to smooth out irregularities.**
- d. Protect completed work from water penetration and runoff.
- e. Allow the base coat to cure a minimum of 24 hours before proceeding with application of finish coat. Cool, damp conditions may require longer drying times. Do not apply finish to a wet or damp base coat.
2. Panzer Mesh Base Coat (Panzer 15 or Panzer 20 used in conjunction with Standard or Standard Plus Reinforcing Mesh). **Panzer Mesh is recommended for use at all ground floor locations and at high traffic areas. Refer to contract documents.**
  - a. Using a stainless steel trowel, apply the base coat mixture on the entire surface of the insulation board to an area slightly larger than the width and length of a piece of reinforcing mesh, in a uniform thickness of approximately 3.2 mm (1/8 in).
  - b. Immediately place the reinforcing mesh against the wet base coat mixture. With the curve of the mesh against the wall, trowel from the center to the edges avoiding wrinkles until the mesh is fully covered and not visible.
  - c. Continue in the same manner until the entire area requiring Panzer Mesh is covered.  
**CAUTION: Do not lap the Panzer Mesh. Adjacent pieces are to be tightly butted.**
  - d. Protect completed work from water penetration and runoff.
  - e. Allow the Panzer base coat to cure a minimum of 24 hours prior to applying Dryvit's Standard or Standard Plus Reinforcing Mesh.
  - f. Apply the second layer of reinforcing mesh in accordance with Section IX.E.1.c. Offset the edges of the Standard or Standard Plus Reinforcing Mesh from the edges of the Panzer Mesh a minimum of 203 mm (8 in). **Tip: If Panzer Mesh is installed horizontally, we recommend the Standard or Standard Plus Mesh be installed vertically and vice versa.**

#### X. Sealant Joint Preparation

- A. All Outsulation Plus MD base coat surfaces which will be in contact with sealant must be coated with either Color Prime or Demandit.
  1. Mix Color Prime or Demandit in accordance with Section III.E and H respectively.
  2. Using a small brush, apply Color Prime or Demandit to the base coat surface that is to be in contact with the sealant and extending to the joint edge.
  3. Allow the Color Prime or Demandit to dry a minimum of 48 hours prior to applying the sealant primer and sealant. Cool damp weather may require longer drying times.
  4. Refer to sealant manufacturer's installation instructions for the proper application of the sealant.

#### XI. Dryvit Primers

- A. Prior to applying the Dryvit primers, the base coat shall have cured a minimum of 24 hours and shall be dry and hard. Cure time may be longer depending on environmental conditions. **NOTE: Refer to Product Data Sheets when applying over other materials.**
- B. Inspect the base coat for any irregularities such as trowel marks, board lines, rough corners and edges, improper reinforcing mesh embedment as well as efflorescence. **NOTE: Correct all irregularities and remove all efflorescence prior to applying the Dryvit primer.**
- C. Color Prime and Weatherprime
  1. Mix to a smooth homogeneous consistency in accordance with Section III.E.
  2. Apply with a brush, roller, or airless spray equipment. Refer to Color Prime or Weatherprime Data Sheets, DS410 or DS436 respectively for complete instructions.
- D. Color Prime W
  1. Mix to a smooth homogeneous consistency in accordance with Section III.E.
  2. Application with airless spray equipment is recommended. Refer to Color Prime W Data Sheet, DS474 for complete instructions.
- E. Primer with Sand
  1. Mix to a smooth homogeneous consistency in accordance with Section III.E.
  2. Application with a roller is recommended. Refer to Primer with Sand Data Sheet, DS477 for complete instructions.

#### XII. Dryvit Finish

- A. Prior to applying the Dryvit finish, the base coat shall have cured a minimum of 24 hours and shall be dry and hard. Cure time may be longer depending on environmental conditions.
- B. Inspect the base coat for any irregularities such as trowel marks, board lines, rough corners and edges, improper reinforcing mesh embedment as well as efflorescence. **NOTE: Correct all irregularities and remove all efflorescence prior to applying the Dryvit finish.**

## C. Application

## 1. General

- a. Important: All Dryvit finishes must be installed continuously to a natural break such as corners, expansion joints, or tapeline. Mechanics must maintain a wet edge. Whenever possible, order enough material in a single batch to complete the project to avoid potential color variations from batch to batch. Sufficient personnel and scaffolding must be provided to continuously finish a distinct wall area or otherwise cold joints will result. Scaffolding must be spaced a minimum of 458 mm (18 in) from the wall to prevent staging lines. On hot windy days, the wall may be fogged with clean potable water to cool the wall and facilitate finish installation. As with other plaster materials, installation work should precede the sun. For example, work the shady or cool side of the building. If this is not possible, scaffold should be shaded with a tarp or nursery shade cloth. Do not introduce water to the finish material once it is installed on the wall. This will cause color variations. Each mechanic must use the same tool and hand motion and match the texture of the mechanics above, below and on each side. Use finish from a single batch number whenever possible.
- b. Do not apply Dryvit materials in the rain. The base coat must be dry prior to applying the Dryvit finish or coatings.
- c. Do not apply textured Dryvit finish material in sealant joints. Refer to Section X for proper sealant joint preparation.

## 2. Quarzputz, Quarzputz E, Sandblast, Weatherlastic Quarzputz

- a. Mix the Dryvit finish as described in Section III.F.
- b. Using a clean stainless steel trowel, apply a coat of the Dryvit finish in a uniform thickness on the dry base coat. **NOTE: The Dryvit Quarzputz finish shall be applied and leveled to a uniform thickness no greater than the largest aggregate. The Sandblast finish is applied and leveled to a thickness of approximately 1 1/2 times the largest aggregate.**
- c. The texture is achieved by uniform hand motion and/or tool that produces the texture to match the approved sample. Each mechanic must use the same tool and hand motion to ensure that the texture achieved is uniform over the entire wall area.

## 3. Sandpebble, Sandpebble E, Sandpebble Fine, Sandpebble Fine E, Weatherlastic Sandpebble, Weatherlastic Sandpebble Fine, Sandpebble FM and Sandpebble Fine FM

- a. Mix the Dryvit finish as described in Section III.F.
- b. Using a clean, stainless steel trowel, apply an even coat of the finish to a thickness slightly thicker than the largest aggregate size.
- c. Pull across using a horizontal trowel motion to develop a uniform thickness no greater than the largest aggregate of the material.
- d. The texture is achieved by a uniform hand floating motion with a clean stainless steel trowel; wipe the trowel and wet it lightly. Apply light pressure in a circular motion.

## 4. Freestyle

- a. Mix the Dryvit finish as described in Section III.F.
- b. Using a clean, stainless steel trowel, apply the Freestyle finish on the base coat in a thickness not greater than 1.6 mm (1/16 in). The texture is either pulled out of this base to a thickness of no greater than 6.4 mm (1/4 in) or the texture may be achieved by adding more Freestyle finish to the base coat using the same texturing motions that are used with other plaster materials, such as, a skip trowel finish. Numerous other aesthetically pleasing textures can be created to match approved samples. **NOTE: The maximum thickness of Freestyle finish texture shall not exceed 6.4 mm (1/4 in).**

## 5. Weatherlastic Adobe

- a. Using a brush, roller or airless spray equipment, apply a coat of color coordinated Color Prime (see Section III.E for mixing instructions) at the recommended coverage to the cured base coat and allow to dry.
- b. Mix the Weatherlastic Adobe finish material as described in Section III.F.
- c. Using a stainless steel trowel, apply a coat of Weatherlastic Adobe approximately 1.6 mm (1/16 in) to the wall surface. Allow the Weatherlastic Adobe finish to take-up.
- d. Using a stainless steel trowel, apply a second coat of Weatherlastic Adobe to obtain the desired texture. **Tip: An atomizing spray bottle may be used to apply a mist of water to the surface in the finishing step.**

## 6. Ameristone

- a. Mix the Ameristone finish as described in Section III.G.1.
- b. Apply Ameristone finish in accordance with Ameristone Application Instructions, DS142.

## 7. Stone Mist

- a. Mix the Stone Mist finish as described in Section III.G.2.
- b. Apply Stone Mist finish in accordance with Stone Mist Data Sheet, DS420.

8. TerraNeo
  - a. Mix the TerraNeo finish as described in Section III.G.3.
  - b. Apply TerraNeo finish in accordance with TerraNeo Data Sheet, DS481.
9. Limestone
  - a. Mix the Limestone finish as described in Section III.G.4.
  - b. Apply Limestone finish in accordance with Limestone Data Sheet, DS472.
10. Custom Brick
  - a. Refer to Dryvit Custom Brick Application Instructions, DS154 for complete installation instructions.
11. Mojave E™
  - a. Refer to Mojave E product Data Sheet DS706.
12. Reflectit
  - a. Refer to Reflectit product Data Sheet, DS705 and Application Instructions DS124.

### XIII. Coatings and Sealers

#### A. Demandit and Weathercoat

1. Mix to a smooth homogeneous consistency in accordance with Section III.H.1.
2. Apply with a brush, roller, or airless spray equipment.
3. When applying with a roller, a maximum 19 mm (3/4 in) nap, polyester or polyester blend with nylon or lambswool, with beveled ends and a phenolic core is recommended. A 458 mm (18 in) wide roller frame with a 57 mm (2 1/4 in) inside diameter is also recommended.
4. Apply in one continuous coat, maintaining a wet edge as the application proceeds to a natural break. The roller cover must be kept fully loaded as the application proceeds. **CAUTION: Do not stretch out the application by rolling with a dry roller. The last leveling roller strokes should always be in the same direction. Do not cut in around openings prior to overall application, but rather, do the cut-in work as the application proceeds.**
5. Do not allow Demandit or Weathercoat to dry on roller covers. Roller covers with dried coating do not apply the coating evenly.
6. Changing color requires the application of two coats.

#### B. Revyvit

1. Mix the Revyvit to a smooth homogeneous consistency in accordance with Section III.H.1.
2. Apply the Revyvit with a brush or 12.7 mm – 15.9 mm (1/2 in - 5/8 in) nap roller.
3. Roll or brush in multiple directions and then lightly finish in one direction to ensure that no lap marks remain.
4. A second coat may be required for heavy textured surfaces or when there is a contrast of colors. Apply the second coat as described in paragraph XIII.B.2 and 3 above. **CAUTION: Do not attempt to apply Revyvit in one heavy coat. Two coats are recommended. Apply the second coat only after the first coat is completely dry. Important: Texture changes will exist after Revyvit is applied over existing Dryvit finishes. The degree of change is a function of the thickness and the number of coats of Revyvit.**

#### C. Weatherlastic Smooth

1. Mix the Weatherlastic Smooth to a smooth, homogeneous consistency in accordance with Section III.H.1.
2. Apply a minimum 11 mils dry film thickness (22 mils wet film thickness). This is achieved by applying the Weatherlastic Smooth in two (2) 11 mil wet coats. Under average drying conditions, 21 °C (70 °F), 50% RH, two (2) hours drying time between coats should be adequate.
3. For cutting-in and trim, a nylon bristle brush is recommended.
4. Roller Application
  - a. A minimum 254 mm (10 in) roller cover with a 32 mm - 38 mm (1 1/4 in - 1 1/2 in) nap is recommended.
  - b. Completely saturate the roller cover and keep the roller loaded with coating to avoid foaming. Do not dry-roll or over-roll as this will cause excessive entrapment of air within the coating.
  - c. A second coat is applied in a similar manner after the first coat has adequately dried.
5. Spray Application
  - a. Application by airless spray equipment or mastic pump and gun allows application of coating at total required application rate with a minimum of stipple or thickness variations.
  - b. Equipment should have the capacity to pump 7.6 L (2 gal) of coating per minute.
  - c. Material hose should be minimum 12.7 mm (1/2 in) inside diameter for spraying coating through more than a 15 m (50 ft) length. Minimum bursting of 3600 N (800 lbs) is recommended. **Tip: Orifice sizes of 0.53 mm - 0.81 mm (0.021 in - 0.032 in) will be required depending on equipment used.**
  - d. Cross apply coating holding spray gun perpendicular to, and approximately 1 m (3 ft) from the wall surface. Avoid excessive material build-up by holding spray gun away from the wall when pulling the trigger, then bringing gun across area to be coated. Maintain a wet edge and avoid starting and stopping in the middle of the wall. Do not attempt to overreach spray pattern as this may result in appearance of irregular spray pattern. Place scaffolding and equipment to facilitate quick application without numerous interruptions.
  - e. A 10 % loss from overspray should be anticipated.
  - f. Backrolling sprayed areas is recommended to control pinholing on spray applications over porous surfaces.

**D. Tuscan Glaze**

1. Mix Tuscan Glaze to a smooth homogenous consistency in accordance with Section III.H.2. Continuously agitate throughout application to ensure color consistency.
2. Tuscan Glaze is best applied on large areas using a Hudson-type sprayer or airless spray equipment. For smaller areas, Tuscan Glaze is best applied with a paint pad or, depending on the desired results, a roller, paint brush or sponge. Job site mock-ups are required and should represent the actual job site application techniques.
3. Apply Tuscan Glaze evenly in light strokes. If sagging or running occurs, use a sponge or paint pad to correct immediately. Watch for brush or roller lines. If brush or roller lines appear, use a damp sponge, a paint pad or rag to make them disappear before the Tuscan Glaze starts to dry. The wall may be blotted with a camelback sponge to achieve the desired mottled appearance. Check walls throughout the application to insure that uniformity and the desired appearance is achieved.

**E. SealClear**

1. Mix SealClear to a smooth, homogeneous consistency in accordance with Section III.H.3.
2. For application instructions, refer to the SealClear Data Sheet, DS426.

**XIV. Maintenance and Repair**

A. Refer to DryvitCARE EIFS Repair Procedures, DS498.

**DISCLAIMER**

Information contained in this specification conforms to standard detail and product recommendations for the installation of the Dryvit Outsulation Plus MD System products as of the date of publication of this document and is presented in good faith. Dryvit Systems, Inc. assumes no liability, expressed or implied, as to the architecture, engineering or workmanship of any project. To insure that you are using the latest, most complete information, contact Dryvit Systems, Inc., at:

One Energy Way  
West Warwick, RI 02893  
(401) 822-4100

---

Dryvit Systems, Inc.  
One Energy Way  
West Warwick, RI 02893  
(800) 556-7752  
www.dryvit.com

