

STEP #1

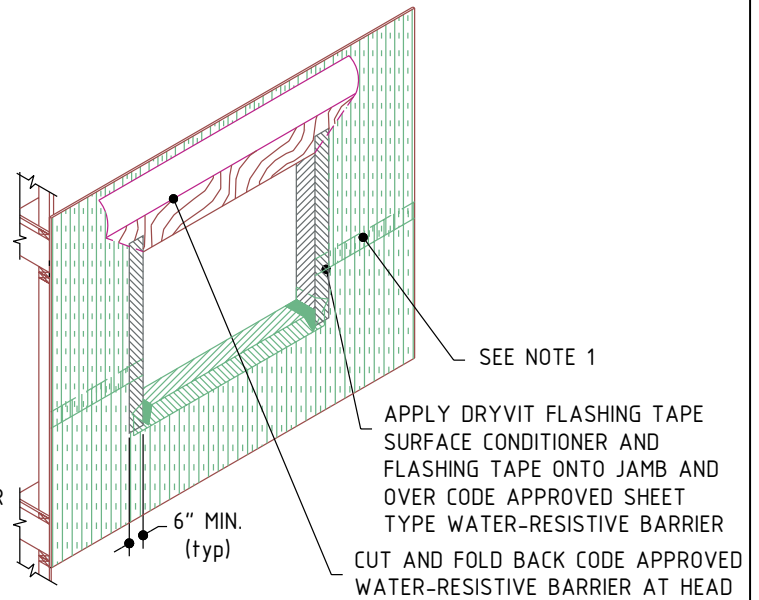

STEP #2

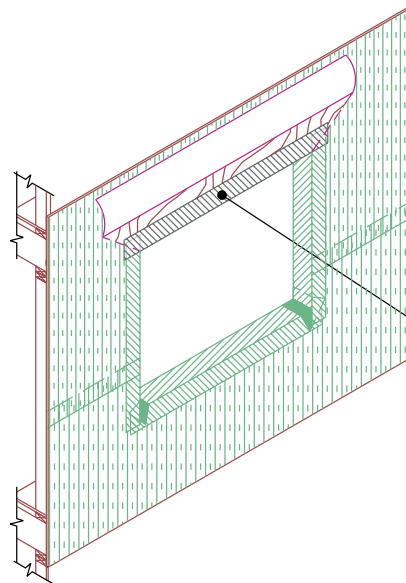

STEP #3

- 1.) APPLY DRYVIT FLASHING TAPE SURFACE CONDITIONER AND DRYVIT FLASHING TAPE ONTO HEAD
- 2.) INSTALL WINDOW UNIT AND ASSOCIATED FLASHINGS PER MANUFACTURER'S RECOMMENDATIONS, CODE REQUIREMENTS AND PROJECT DOCUMENTS.
- 3.) FOLD DOWN WATER-RESISTIVE BARRIER OVER HEAD FLASHING AND TAPE SEAMS WITH DRYVIT FLASHING TAPE

Outsulation® RMD System™

Opening Prep - Sheet Type WRB

NOTE:

1. SHEET TYPE CODE APPROVED WATER-RESISTIVE BARRIER SHALL BE INSTALLED IN A WEATHER BOARD FASHION IN ACCORDANCE WITH CODE AND MANUFACTURER'S REQUIREMENTS.
2. DRYVIT OPENING WRAP SHALL EXTEND TO THE INTERIOR FACE OF FRAMING

The architecture, engineering and design of the project using the Dryvit products is the responsibility of the project's design professional. All systems must comply with local building codes and standards. This detail is for general information and guidance only and Dryvit specifically disclaims any liability for the use of this detail and for the architecture, design, engineering or workmanship of any project. The project design professional determines, in its sole discretion, whether this detail or a functionally equivalent alternative is best suited for the project. Use of a functionally equivalent detail does not violate Dryvit's warranty. This detail is subject to change without notice. Contact Dryvit to insure you have the most recent version.

APPROVED BY:	REV:	DATE:
RS	1	02/08

