

REFER TO OPMD 0.0.05, AND 0.0.06 FOR PREPARATION OF OPENING PRIOR TO FLASHING APPLICATION

STEP #1

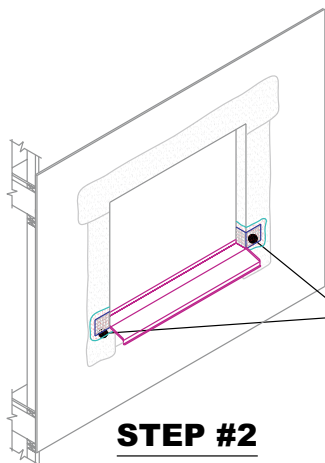

APPLY DRYVIT AQUAFLASH® SYSTEM SPLICES LAPPING OVER LIP OF SILL PAN FLASHING. (SEE NOTES 1 AND 2)

STEP #2

REFER TO OPMD 0.0.11 FOR JAMB DETAIL

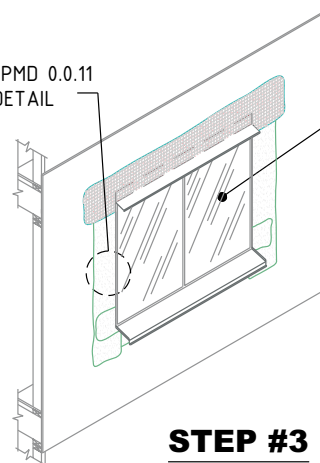

INSTALL WINDOW UNIT AND ASSOCIATED FLASHINGS AND APPLY DRYVIT AQUAFLASH SYSTEM OVER VERTICAL LEG OF FLASHING (SEE NOTES 1 AND 2)

STEP #3

Outsulation[®] Plus MD System[®]

Opening Flashing Integration

NOTE:

1. REFER TO OPMD 0.0.08, 0.0.09 FOR INTEGRATION OF FLASHING.
2. DRYVIT FLASHING TAPE SURFACE CONDITIONER™ AND DRYVIT FLASHING TAPE™ MAY BE USED LIEU OF DRYVIT AQUAFLASH SYSTEM.

The architecture, engineering and design of the project using the Dryvit products is the responsibility of the project's design professional. All systems must comply with local building codes and standards. This detail is for general information and guidance only and Dryvit specifically disclaims any liability for the use of this detail and for the architecture, design, engineering or workmanship of any project. The project design professional determines, in its sole discretion, whether this detail or a functionally equivalent alternative is best suited for the project. Use of a functionally equivalent detail does not violate Dryvit's warranty. This detail is subject to change without notice. Contact Dryvit to insure you have the most recent version.

APPROVED BY:	REV:	DATE:
RS	3	03/08