

APPLY DRYVIT GRID TAPE™
(SEE NOTES 1 AND 2)

STEP #1

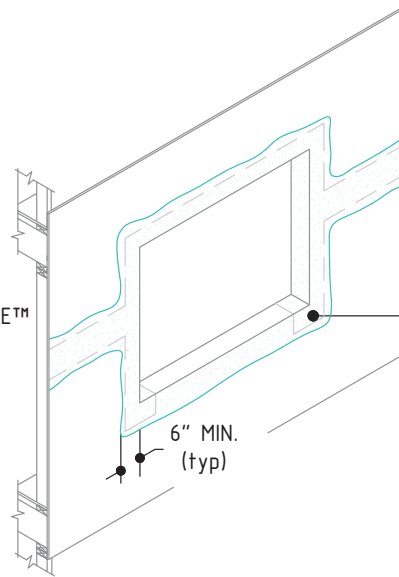

TROWEL APPLY DRYVIT
BACKSTOP NT-TEXTURE
(SEE NOTE 2)

6" MIN.
(typ)

STEP #2

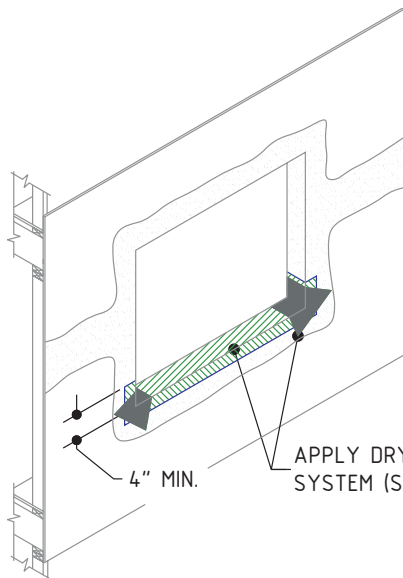

APPLY DRYVIT AQUAFASH®
SYSTEM (SEE NOTES 2, 3 AND 5)

4" MIN.

STEP #3

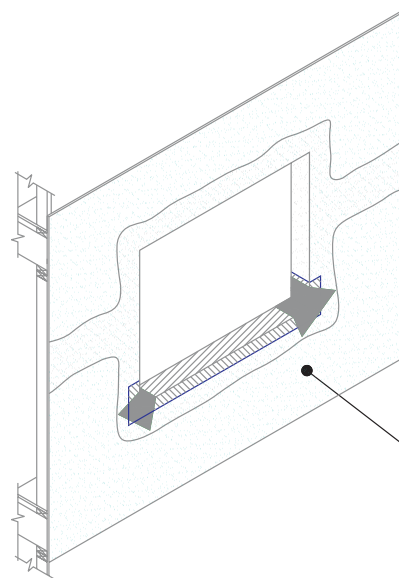

DRYVIT WATER-RESISTIVE
BARRIER COATING APPLIED
TO FACE OF WALL
(SEE NOTE 5)

STEP #4

Outsulation® MD System®

Opening Preparation- Backstop® NT Option

NOTE:

1. APPLY DRYVIT GRID TAPE ON CORNERS OF OPENING AND SHEATHING JOINTS.
2. TROWEL APPLY DRYVIT BACKSTOP NT-TEXTURE OVER THE DRYVIT GRID TAPE ALL THE WAY TO INSIDE FACE OF OPENING. ALL VOIDS MUST BE FILLED; MULTIPLE PASSES MAY BE REQUIRED. AS AN OPTION, DRYVIT GRID TAPE AND DRYVIT BACKSTOP NT-TEXTURE MAY ALSO BE APPLIED AT THE SILL PRIOR TO DRYVIT AQUAFASH SYSTEM OR FLASHING TAPE APPLICATION.
3. DRYVIT FLASHING TAPE SURFACE CONDITIONER™ AND DRYVIT FLASHING TAPE™ MAY BE USED IN LIEU OF AQUAFASH SYSTEM AT SILL, INCLUDING CORNER SPLICES.
4. INSTALL WINDOW UNIT AND ASSOCIATED FLASHINGS PER MANUFACTURER'S RECOMMENDATIONS, CODE REQUIREMENTS AND PROJECT DOCUMENTS.
5. REFER TO HEAD, SILL AND JAMB DETAILS FOR FLASHING INTEGRATION

The architecture, engineering and design of the project using the Dryvit products is the responsibility of the project's design professional. All systems must comply with local building codes and standards. This detail is for general information and guidance only and Dryvit specifically disclaims any liability for the use of this detail and for the architecture, design, engineering or workmanship of any project. The project design professional determines, in its sole discretion, whether this detail or a functionally equivalent alternative is best suited for the project. Use of a functionally equivalent detail does not violate Dryvit's warranty. This detail is subject to change without notice. Contact Dryvit to insure you have the most recent version.

APPROVED BY:	REV:	DATE:
RS	1	09/06

