



## LISTING INFORMATION OF Dryvit - Category 1 OUTSULATION EIFS Wall Systems

SPEC ID: 29311

Dryvit Systems Canada  
129 Ringwood Drive  
Stouffville, ON, L4A 8A2  
Canada

This report is for the exclusive use of Intertek's Client and is provided pursuant to the agreement between Intertek and its Client. Intertek's responsibility and liability are limited to the terms and conditions of the agreement. Intertek assumes no liability to any party, other than to the Client in accordance with the agreement, for any loss, expense or damage occasioned by the use of this report. Only the Client is authorized to permit copying or distribution of this report and then only in its entirety. Any use of the Intertek name or one of its marks for the sale or advertisement of the tested material, product or service must first be approved in writing by Intertek. The observations and test results in this report are relevant only to the sample tested. This report by itself does not imply that the material, product, or service is or has ever been under an Intertek certification program.

DRYVIT OUTSULATION® WALL SYSTEM  
 DRYVIT OUTSULATION® PLUS WALL SYSTEM  
 DRYVIT OUTSULATION® MD WALL SYSTEM  
 DRYVIT OUTSULATION® PE WALL SYSTEM  
 DRYVIT OUTSULATION® PD WALL SYSTEM

Dryvit OUTSULATION® Wall Systems are Exterior Insulation and Finish Systems (EIFS) consisting of an adhesive, expanded polystyrene insulation board, base coat, reinforcing mesh and a finish coat. The systems can also be mechanically attached through the expanded polystyrene insulation board into approved substrates. Refer to Design Listings DSC/DAFS 25-01, DSC/WEIFS 25-01 and DSC/DAFS 25-02 for detailed specifications on each system.

## RATINGS

Standard	Rating	Design Number
CAN/ULC S134	Flame Spread: < 5.0 m Heat Flux at 3.5 m: < 35 kW/m <sup>2</sup>	DSC/DAFS 25-01, DSC/WEIFS 25-01 and DSC/DAFS 25-02

<u>Attribute</u>	<u>Value</u>
CSI Code	07 24 00 Exterior Insulation and Finish Systems (EIFS)
Listed or Inspected	LISTED
Report Number	3008581; 3140833; 3172311; 100182049; 100742658
Criteria	CAN / ULC S134 (1992)
Intertek Services	Certification
Listing Section	WALL EXTERIOR INSULATION & FINISH SYSTEMS (EIFS)

## DRAWING INDEX

DSC-WEIFS 25-01

DSC-DAFS 25-01

DSC-DAFS 25-02

# DSC-WEIFS 25-01

Division 7 – Thermal and Moisture Protection  
 07 24 00 Exterior Insulation and Finish Systems  
 07 24 19 Water-Drainage Exterior Insulation and Finish Systems

Page 1 of 2

Design Number: DSC/WEIFS 25-01  
 EXTERIOR WALL SYSTEMS  
 Dryvit Systems Canada  
 Dryvit OUTSULATION® MD and OUTSULATION® PE  
 CAN/ULC S134 (1992)  
 Meets the Requirements of Article 3.1.5.5 of the National Building Code of Canada, 2010

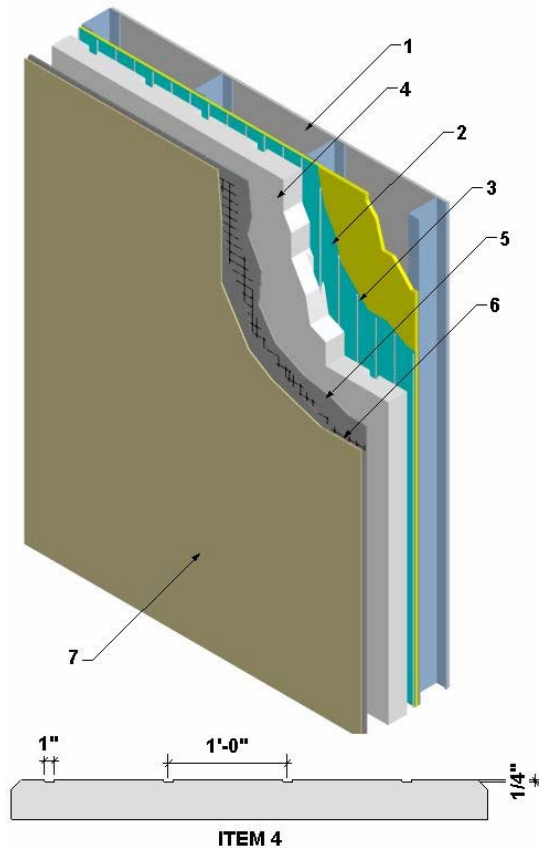

1. NON LOADBEARING WALL ASSEMBLY: Construct a non-loadbearing wall assembly that shall comply with the local Building Code or other applicable regulatory requirements when those are greater.
2. WATER RESISTIVE BARRIER: Apply one of the following membrane systems
  - A. DryvitDryflex™: Polymer based cementitious air/moisture barrier applied in accordance with manufacturers instructions or,
  - B. Dryvit Backstop NT™/NT VB: Polymer based non-cementitious

to the exterior side of the non loadbearing wall assembly (Item 1):

Date Created: December 6, 2012  
 Project No: 100742658MID-001b



©Intertek

**DSC-WEIFS 25-01 (page 2 of 2)****Division 7 – Thermal and Moisture Protection  
07 24 00 Exterior Insulation and Finish Systems****07 24 19 Water-Drainage Exterior Insulation and Finish Systems**

Page 2 of 2

air/moisture barrier applied in accordance with manufacturers instructions.

amount of water may be added to achieve working viscosity).

3. **ADHESIVE:** Install Dryvit adhesive (item 5) and apply using a 1/2 in. x 1/2 in. notched trowel. Adhesive ribbons shall run vertically and measure approximately 3/8 in. (9mm) when formed and will be compressed when adhered to the substrate.
4. **INSULATION BOARD:** Secure insulation board using adhesive (Item 3). Use minimum 2 in. (51 mm) thick and maximum 4 in. (102 mm) thick, 1 pcf, expanded polystyrene (EPS) board manufactured under a quality assurance program and conforming to CAN/ULC S701 Type 1 (flame spread rating less than 500 per CAN/ULC S102.2). Insulation board has profile consisting of .25-.40 in. (6-10 mm) by 1 in. (25 mm) grooves running vertically on the interior side of the board spaced 12 in. (305 mm) oc. All outside edges are to be chamfered.
5. **BASE COAT:** Apply one of the following base coat applications to the exterior side of the insulation board (Item 4). After the initial coat, apply reinforcing mesh (Item 6) and then additional coats so that the mesh (Item 6) is completely embedded and the final thickness of the base coat is minimum 1/12 in. (2 mm).
  - A. Dryvit Primus Adhesive/Base Coat: mixed at a 1:1 ratio by weight with Type GU Portland cement (a small amount of water may be added to achieve working viscosity) or,
  - B. Primus DM Adhesive/Base Coat: mixed at a 4:1 ratio with clean potable water or,
  - C. Primus DM+ Adhesive/Base Coat: mixed at a 4:1 ratio with clean potable water or,
  - D. Genesis Adhesive/Base Coat: mixed at 1:1 ratio by weight with Type GU Portland cement (a small
- E. Genesis DM Adhesive/Base Coat: mixed at a 4:1 ratio with clean potable water or,
- F. Rapidry 50/75 Adhesive Base Coat: mixed at a 4:1 ratio with clean potable water.
6. **REINFORCING MESH:** Apply Dryvit mesh, either "Standard®", "Standard® Plus", Intermediate Mesh 0.49 – 1.22 oz/ft<sup>2</sup> self-extinguishing, edges overlapped 3 in. (75 mm) minimum and embedded into the base coat (Item 5). The fiberglass mesh is back-wrapped at the panel edges and joints of the substrate to encapsulate the insulation board. For additional impact resistance, a layer of Dryvit Panzer® Meshes 1.6 – 2.2 oz/ft<sup>2</sup> may be applied to the system prior to the application of standard meshes in accordance with the manufacturer's application procedures.
7. **FINISH COAT:** Apply Dryvit "DPR" finish, StoneMist, TerraNeo, Amerisone, LymeStone, Custom Brick, and smooth coatings over the base coat (Item 5) in accordance with Dryvit's installation guidelines for the specific finish using stainless steel trowel.
8. **Optional Mechanical Fastening (Not Shown):** Where supplemental mechanical fastening is to be used for restraining the EPS to substrate, GridmateClass PB(TM), or Wind-Devil 2 washers and fasteners can be used for penetrating through the EPS into the component substrate. Details of this installation can be found in Dryvit's product literature.

Date Created: December 6, 2012  
Project No: 100742658MID-001b



©Intertek

# DSC-DAFS 25-01

Division 7 – Thermal and Moisture Protection  
07 24 00 Exterior Insulation and Finish Systems  
07 24 23 Direct Applied Finish Systems

Page 1 of 2

---

Design Number: DSC/DAFS 25-01  
EXTERIOR WALL SYSTEMS  
Dryvit Systems Canada  
Dryvit OUTSULATION® and OUTSULATION® PLUS  
CAN/ULC S134 (1992)  
Meets the Requirements of Article 3.1.5.5 of the National Building Code of Canada, 2010

---

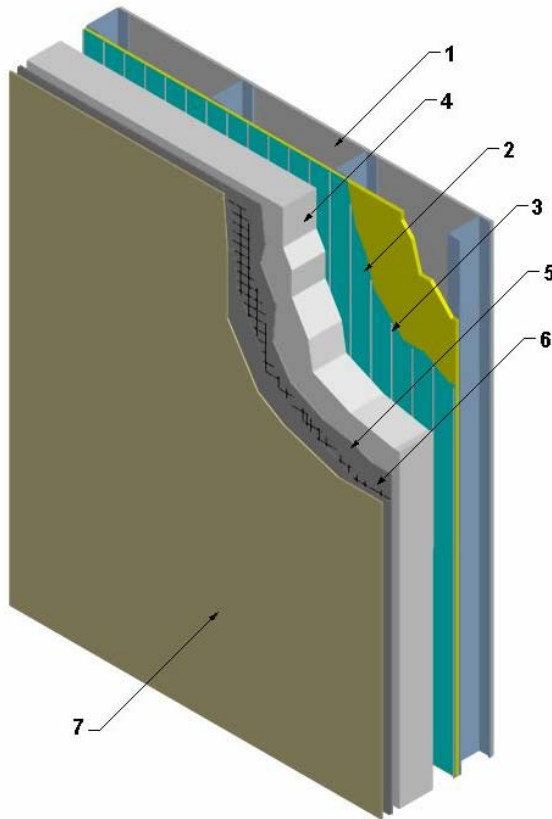

1. NON LOADBEARING WALL ASSEMBLY: Construct a non-loadbearing wall assembly that shall comply with the local Building Code or other applicable regulatory requirements when those are greater.
2. WATER RESISTIVE BARRIER: Apply one of the following membrane systems

to the exterior side of the non loadbearing wall assembly (Item 1):

- A. DryvitDryflex™: Polymer based cementitious air/moisture barrier applied in accordance with manufacturers instructions or,
- B. Dryvit Backstop NT™/NT VB: Polymer based non-cementitious

Date Created: December 6, 2012  
Project No: 100742658MID-001A



©Intertek

**DSC-DAFS 25-01 (page 2 of 2)****Division 7 – Thermal and Moisture Protection  
07 24 00 Exterior Insulation and Finish Systems  
07 24 23 Direct Applied Finish Systems**

Page 2 of 2

air/moisture barrier applied in accordance with manufacturers instructions.

Type GU Portland cement (a small amount of water may be added to achieve working viscosity).

3. **ADHESIVE:** Install Dryvit adhesive (item 5) and apply using a 1/2 in. x 1/2 in. notched trowel. Adhesive ribbons shall run vertically and measure approximately 3/8 in. (9mm) when formed and will be compressed when adhered to the substrate.
4. **INSULATION BOARD:** Secure insulation board using adhesive (Item 3). Use maximum 4 in. (102 mm) thick, 1 pcf, expanded polystyrene (EPS) board manufactured under a quality assurance program and conforming to CAN/ULC S701 Type 1 (flame spread rating less than 500 per CAN/ULC S102.2).
5. **BASE COAT:** Apply one of the following base coat applications to the exterior side of the insulation board (Item 4). After the initial coat, apply reinforcing mesh (Item 6) and then additional coats so that the mesh (Item 6) is completely embedded and the final thickness of the base coat is minimum 1/12 in. (2 mm).
  - A. Dryvit Primus Adhesive/Base Coat: mixed at a 1:1 ratio by weight with Type GU Portland cement (a small amount of water may be added to achieve working viscosity) or,
  - B. Primus DM Adhesive/Base Coat: mixed at a 4:1 ratio with clean potable water or,
  - C. Primus DM+ Adhesive/Base Coat: mixed at a 4:1 ratio with clean potable water or,
  - D. Genesis Adhesive/Base Coat: mixed at 1:1 ratio by weight with
- E. Genesis DM Adhesive/Base Coat: mixed at a 4:1 ratio with clean potable water or,
- F. Rapidry 50/75 Adhesive Base Coat: mixed at a 4:1 ratio with clean potable water.
6. **REINFORCING MESH:** Apply Dryvit mesh, either "Standard@", "Standard@ Plus", Intermediate Mesh 0.49 – 1.22 oz/ft<sup>2</sup> self-extinguishing, edges overlapped 3 in. (75 mm) minimum and embedded into the base coat (Item 5). The fiberglass mesh is back-wrapped at the panel edges and joints of the substrate to encapsulate the insulation board. For additional impact resistance, a layer of Dryvit Panzer@ Meshes 1.6 – 2.2 oz/ft<sup>2</sup> may be applied to the system prior to the application of standard meshes in accordance with the manufacturer's application procedures.
7. **FINISH COAT:** Apply Dryvit "DPR", StoneMist, TerraNeo, Ameristone, LymeStone, Custom Brick, and smooth coatings over the base coat (Item 5) in accordance with Dryvit's installation guidelines for the specific finish using stainless steel trowel.
8. **Optional Mechanical Fastening (Not Shown):** Where supplemental mechanical fastening is to be used for restraining the EPS to substrate, GridmateClass PB(TM), or Wind-Devil 2 washers and fasteners can be used for penetrating through the EPS into the component substrate. Details of this installation can be found in Dryvit's product literature.

Date Created: December 6, 2012  
Project No: 100742658MID-001A



©Intertek

# DSC-DAFS 25-02

Division 7 – Thermal and Moisture Protection  
 07 24 00 Exterior Insulation and Finish Systems  
 07 24 23 Direct Applied Finish Systems

Page 1 of 2

Design Number: DSC/DAFS 25-02  
 EXTERIOR WALL SYSTEMS  
 Dryvit Systems Canada  
 Dryvit OUTSULATION® PD  
 CAN/ULC S134 (1992)

Meets the Requirements of Article 3.1.5.5 of the National Building Code of Canada, 2010

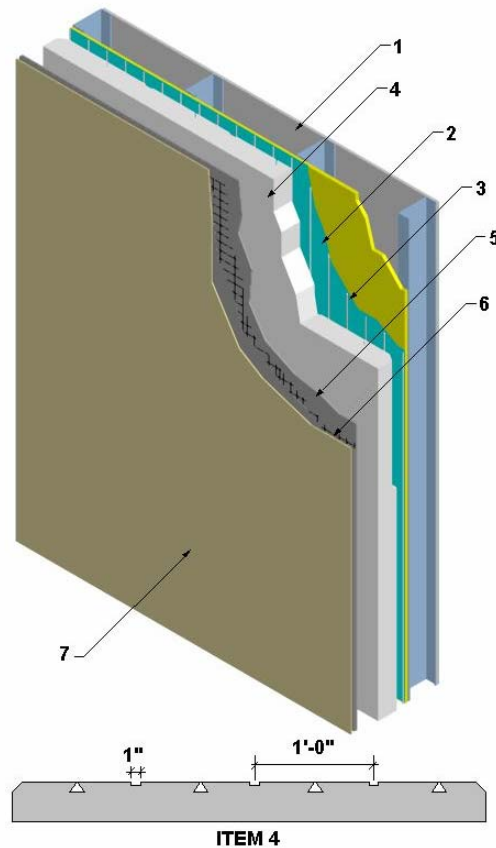

1. NON LOADBEARING WALL ASSEMBLY: Construct a non-loadbearing wall assembly that shall comply with the local Building Code or other applicable regulatory requirements when those are greater.
2. WATER RESISTIVE BARRIER: Apply one of the following membrane systems

to the exterior side of the non loadbearing wall assembly (Item 1):

- A. DryvitDryflex™: Polymer based cementitious air/moisture barrier applied in accordance with manufacturers instructions or,
- B. Dryvit Backstop NT™/NT VB: Polymer based non-cementitious

Date Created: December 6, 2012  
 Project No: 100742658MID-001c



©Intertek



**DSC-DAFS 25-02 (page 2 of 2)****Division 7 – Thermal and Moisture Protection  
07 24 00 Exterior Insulation and Finish Systems  
07 24 23 Direct Applied Finish Systems**

Page 2 of 2

- air/moisture barrier applied in accordance with manufacturers instructions.
3. **ADHESIVE:** Install Dryvit adhesive (item 5) and apply using a 1/2 in. x 1/2 in. notched trowel. Adhesive ribbons shall run vertically and measure approximately 3/8 in. (9mm) when formed and will be compressed when adhered to the substrate.
  4. **INSULATION BOARD:** Secure insulation board using adhesive (Item 3). Use minimum 2 in. (51 mm) thick and maximum 4 in. (102 mm) thick, 1 pcf, expanded polystyrene (EPS) board manufactured under a quality assurance program and conforming to CAN/ULC S701 Type 1 (flame spread rating less than 500 per CAN/ULC S102.2). All outside edges are to be chamfered to 0.6 in. (15 mm). Insulation board has profile consisting of three 0.4 in. (10 mm) deep by 1 in. (25 mm) wide rectangular grooves running vertically on the interior side of the board spaced 12 in. (305 mm) oc. Between rectangular grooves are four inverted triangular grooves spaced 12 in. (305 mm) oc. The grooves measure 1-1/2 in. (38 mm) at the base and narrow to 0.08 in. (2 mm) at the peak. The base of the triangles align with the perimeter chamfer at a depth of 0.6 in. (15 mm).
  5. **BASE COAT:** Apply one of the following base coat applications to the exterior side of the insulation board (Item 4). After the initial coat, apply reinforcing mesh (Item 6) and then additional coats so that the mesh (Item 6) is completely embedded and the final thickness of the base coat is minimum 1/12 in. (2 mm).
    - A. Dryvit Primus Adhesive/Base Coat: mixed at a 1:1 ratio by weight with Type GU Portland cement (a small amount of water may be added to achieve working viscosity) or,
    - B. Primus DM Adhesive/Base Coat: mixed at a 4:1 ratio with clean potable water or,
    - C. Primus DM+ Adhesive/Base Coat: mixed at a 4:1 ratio with clean potable water or,
    - D. Genesis Adhesive/Base Coat: mixed at 1:1 ratio by weight with Type GU Portland cement (a small amount of water may be added to achieve working viscosity).
    - E. Genesis DM Adhesive/Base Coat: mixed at a 4:1 ratio with clean potable water or,
    - F. Rapidry 50/75 Adhesive Base Coat: mixed at a 4:1 ratio with clean potable water.
  6. **REINFORCING MESH:** Apply Dryvit mesh, either "Standard®", "Standard® Plus", Intermediate Mesh 0.49 – 1.22 oz/ft<sup>2</sup> self-extinguishing, edges overlapped 3 in. (75 mm) minimum and embedded into the base coat (Item 5). The fiberglass mesh is back-wrapped at the panel edges and joints of the substrate to encapsulate the insulation board. For additional impact resistance, a layer of Dryvit Panzer® Meshes 1.6 – 2.2 oz/ft<sup>2</sup> may be applied to the system prior to the application of standard meshes in accordance with the manufacturer's application procedures.
  7. **FINISH COAT:** Apply Dryvit "DPR" finish, StoneMist, TerraNeo, Ameristone, LymeStone, Custom Brick, and smooth coatings over the base coat (Item 5) in accordance with Dryvit's installation guidelines for the specific finish using stainless steel trowel.
  8. **Optional Mechanical Fastening (Not Shown):** Where supplemental mechanical fastening is to be used for restraining the EPS to substrate, GridmateClass PB™, or Wind-Devil 2 washers and fasteners can be used for penetrating through the EPS into the component substrate. Details of this installation can be found in Dryvit's product literature.

Date Created: December 6, 2012  
Project No: 100742658MID-001c

©Intertek